

DRINKING WATER TREATMENT

Eliminate the presence of
pathogens and contaminants

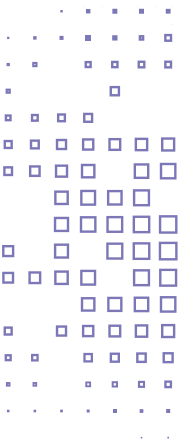

THE MOST EFFECTIVE TECHNOLOGY FOR TREATING CONTAMINATED DRINKING WATER.

There are more than 280 major water treatment plants in the United States that incorporate the use of ozone in their processes. Drinking water treated with ozone kills or inactivates any pathogenic micro-organisms including viruses, bacteria and parasites and removes inorganic trace contaminants found in water system due to pollution. Ozone treatment also reduces naturally occurring organic compounds such as humic acid and algal metabolites.

Surface waters, including lakes and rivers, generally contain higher levels of micro-organisms. Therefore, they are more prone to contamination than groundwater and require different treatment regimes. Ozone Solution's industry-leading technology provides an effective treatment to reduce customer risk and insure compliance to increasingly stricter drinking water regulations being enacted worldwide.

OZONE SOLUTIONS' DRINKING WATER TREATMENT PRODUCTS.

PRODUCTS

○ Waterzone Series



○ Waterzone SE Series



○ Waterzone IS Series



BENEFITS OF OZONE WATER TREATMENT:

BENEFITS

- No environmental or health-endangering by-products due to a reduction of chemical usage
- Lower quantities and less reaction time are required than chemicals such as chlorine
- pH insensitivity
- Produced merely from energy and oxygen/air and reverts back to oxygen after the reaction
- Reduction in energy consumption
- Removal of odors and colors
- Natural taste and smell of the water is preserved
- Disinfection, i.e. killing of microorganisms (giardia lamblia /virus inactivation/elimination of cryptosporidia, and other contaminants)
- No formation of haloforms
- Enhancement of the flocculation/coagulation-decantation process
- Most powerful oxidizer
 - Iron and manganese for effective filtration
 - Hydrogen sulfur or other sulfur based compounds
- Degradation of pesticides, pharmaceutical residues and other trace contamination
- Removal of organic and inorganic matter



I would like to commend Ozone Solutions for their quality workmanship and superior customer service. They were extremely helpful during the engineering, planning, and building process, offering both time-saving and cost-saving ideas to the design of the remedial system. Thank you for your continued professionalism and proficiency.

– Tammy Onorato, PG Operations Manager • Tampa, FL



OVERVIEW OF OZONE DISINFECTION PROCESS.

For disinfection of water with standard levels of minerals, ozone is injected into the tank and after appropriate contact time the water will be ready for use.

OZONE SYSTEM FOR IRON & MANGANESE REMOVAL.

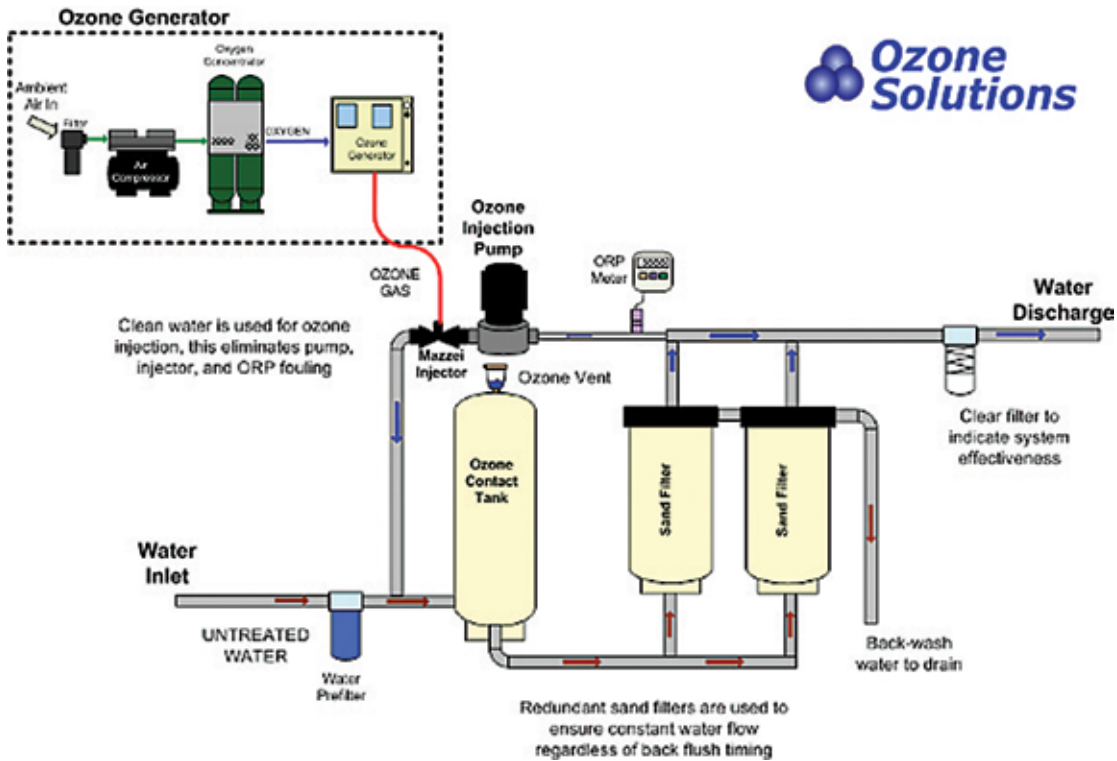

PROCESS



ABOUT OZONE SOLUTIONS

Ozone Solutions Inc., founded in 1997, is a full-service provider of cost-effective and environmentally friendly ozone technology. Our products and services are internationally present in many different applications. We are reaching out to our customers through our global network of distributors as well as our regional sales representatives in North America. Today, Ozone Solutions Inc. is moving forward in company and product development, in order to become the most trusted and innovative supplier of ozone technology.

OZONE SOLUTIONS ADVANTAGES

- Complete project oversight from concept through ongoing usage
- Excellent customer service
- Industry leader in service support
- Research & Development lab
- Customized solutions
- Replacement parts availability
- Customer system operation and maintenance training
- Reliable products for many applications
- Ozone monitors and detection equipment available

APPLICATIONS

- Air Treatment & Odor Control
- Aquaculture & Zoos
- Biofuel
- Bottled Water
- CIP (Clean in Place)
- Cooling Tower
- Dairy
- Drinking Water Treatment
- Food Processing & Storage
- Grain & Feed Remediation
- Groundwater & Soil Remediation
- HVAC
- Laundry
- Livestock
- Medical
- Pharmaceutical
- Pools, Waterpark, & Spas
- Pulp & Paper Bleaching
- Semiconductor Production
- Wastewater Treatment
- Wine & Beer

CONTACT US FOR MORE INFORMATION

Ozone Solutions, Inc.
451 Black Forest Road • Hull, IA 51239
Tel: 1.712.439.6880 | Fax: 1.712.439.6733

Visit us on the web:
www.ozonesolutions.com

Email us:
info@ozonesolutions.com
sales@ozonesolutions.com