



451 Black Forest Rd Hull, IA 51239 Ph: (712) 439-6880 Fax: (712) 439-6733

TS-30

30 g/hr Turnkey Ozone Generation System



Installation and Operation Manual

Cautions, Warnings and Hazards

Ozone is a powerful oxidizing agent. Observe strict operating procedures when using ozone equipment. Ensure that the TS-30 is in a well-ventilated area.

Note: If the operator has asthma, he/she must not enter an ozonated airspace. Ozone can induce an asthma attack.

WARNING Ozone is an extremely aggressive and powerful oxidizer. The Occupational Safety and Health Administration (OSHA) 8-hour exposure limit is 0.10-PPM. The OSHA 15-minute exposure limit for ozone is 0.3 PPM. Above 0.3 PPM, there is the risk of damage to respiratory tissues.

WARNING People who have no sense of smell should not operate this equipment.

WARNING **Never attempt to verify ozone production by directly breathing or smelling the ozone outlet or an ozone-tubing outlet.**

WARNING The system uses ozone compatible Stainless and Teflon tubing. The Ozone Generators under high pressure poses the possibility of ozone leaks to occur. In the event of an ozone leak, immediately shut down the system.

WARNING Use only Teflon or other approved methods for ozone tubing. Ensure tubing connections between the Ozone System and the point of use are secure and in good condition. Failure to do so could result in the discharge of dangerous amounts of ozone into an occupied space.

The TS- 40 contains an OXYGEN CONCENTRATOR (a.k.a. Oxygen Generator) for the production of high concentration oxygen to supply the Ozone Generator.

Although oxygen itself is not combustible, it can be very dangerous. It greatly accelerates the burning of combustible materials.

- Precautions should be taken to avoid a fire in the area of the generator.
- Smoking should not be permitted in the area where the generator is located.
- All oxygen connections and hoses should be kept clean and free of grease, oil and other combustible materials.
- Valves controlling oxygen flow should be opened and closed slowly to avoid the possibility of fires or explosions that can result from adiabatic compression.
- When bleeding a tank or line, stand clear and do not allow oxygen to embed itself within clothing. A spark could ignite the clothing violently.
- High-pressure gases may be present within the system. Valves should be opened and closed slowly. Safety glasses and hearing protection should be worn at all times while gases are being vented.
- Do not attempt to modify or enhance the performance of the Generator in any way.

Table Of Contents

CAUTIONS, WARNINGS AND HAZARDS.....	2
INTRODUCTION.....	4
SYSTEM FLOW DIAGRAM AND THEORY OF OPERATION.....	4
OZONE GENERATOR PERFORMANCE.....	5
<i>Ozone Generator Performance Charts</i>	6
INSTALLATION.....	7
VENTILATION.....	7
LOCATION & MOUNTING.....	8
CONNECTIONS.....	8
<i>Electrical Power</i>	8
<i>Optional Electrical Control Connections</i>	9
<i>Ozone Out & Ozone Flow Control Valve Connection</i>	9
<i>TS-30 Connection Scenarios</i>	10
TS-30 INITIAL STARTUP PROCEDURE.....	11
OPERATION.....	12
OXYGEN CONCENTRATOR (MAIN).....	12
OZONE GENERATOR.....	13
MAINTENANCE SCHEDULE.....	15
SPECIFICATIONS.....	16
HOW TO CONTACT OZONE SOLUTIONS.....	16

Introduction

The TS-30 Ozone Generator is a complete air preparation and ozone generation system. The unit includes an integrated Air Compressor, Oxygen Concentrator, and Ozone Generator. No external air supply is required. Contained within the TS-30 chassis is a TG-40 Ozone Generator, capable of producing 30 gm/hr of ozone at 6% concentration by weight. Using pressurized oxygen from the Oxygen Concentrator, the Ozone Generator will achieve from 2 to 40 gm/hr of ozone production at flows of 1-10 LPM and at pressures of 10-20 PSI.

System Flow Diagram and Theory of Operation

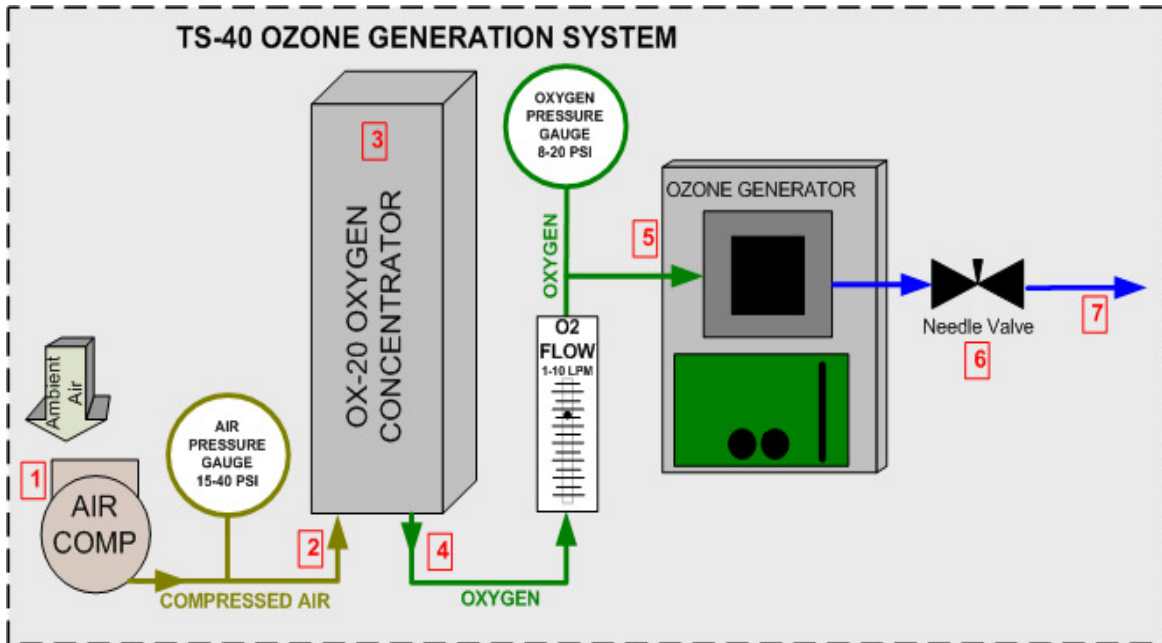

1. Air Compressor takes in ambient air & delivers it to the Oxygen Concentrator.
2. Compressed air enters Oxygen Concentrator.
3. Oxygen Concentrator removes nitrogen from the air using pressure swing absorption, leaving 90-95% oxygen. Effluent nitrogen is vented to atmosphere.
4. 90-95% Oxygen leaves the Oxygen Concentrator at a rate of up to 10 LPM under 8-20 PSI pressure. Pressure & flow are regulated by an internal needle valve downstream of the Ozone Generator, see #6 below.
5. Oxygen enters Ozone Generator where it is utilized to produce high concentration ozone under pressure.
6. Panel mounted Needle Valve will allow adjustment of oxygen flow from the TS-30 Ozone Generator. Oxygen flow must never exceed 10 LPM of flow.
7. Ozone exits TS-30 via the OZONE OUT port.

Ozone Generator Performance

The Ozone Generator is designed to produce ozone from oxygen under pressure. While maximum ozone production (by volume) will be achieved at higher pressures and flows, the Oxygen Concentrator is limited to a given pressure (8-20 PSI) at a given flow (1-10 LPM).

“Optimum” ozone production is dependent on the application. Some applications require higher concentration ozone at a lower flow rate (lower overall production by volume), while others may require maximum overall production by volume (lower concentration). Desired ozone flow can be determined by the user according to the chart on the following page.

Ozone Generator Performance Chart

OZONE GENERATOR PERFORMANCE TEST

TS-30 Ozone Generator

#	Oxygen Flow in LPM	Ozone Concentration, % by weight	Ozone Production in g/hr	COMMENTS
1	1.00	8.02	6.88	
2	2.00	7.65	13.13	
3	3.00	6.75	17.37	
4	4.00	6.23	21.38	
5	5.00	5.50	23.60	
6	6.00	5.06	26.05	
7	7.00	4.82	28.95	
8	8.00	4.35	29.86	
9	9.00	3.98	30.73	
10	10.00	3.65	31.32	

Ozone Production

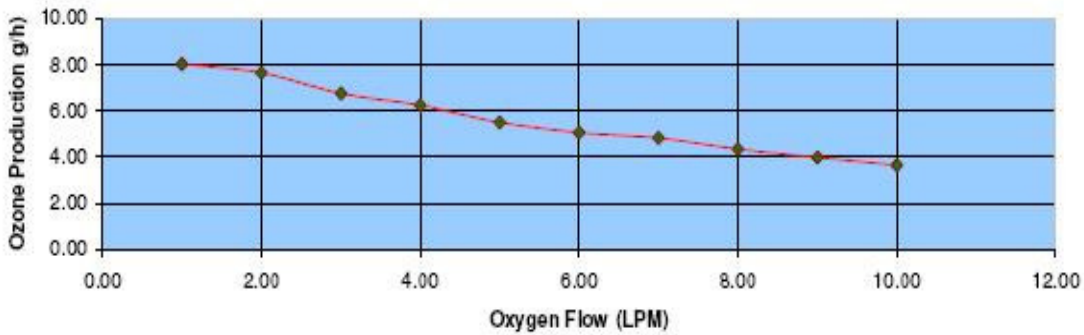

Ozone Concentration

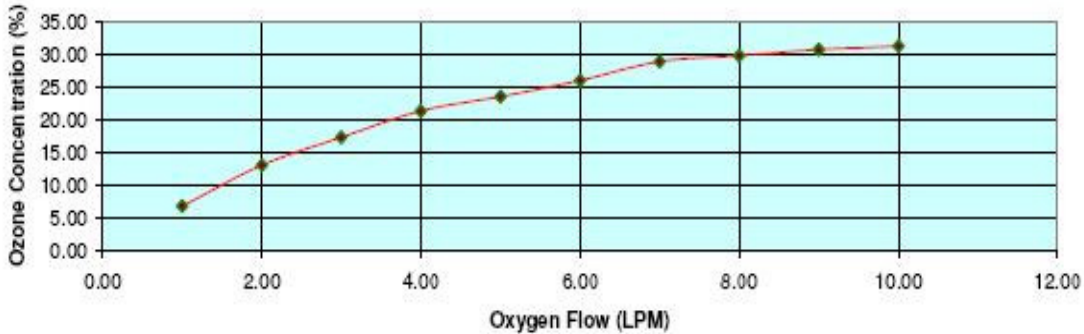

Test was performed at 72°F, Generator was ON for more than 1 hour.
Ozone Analyzer API 460H

Installation

VENTILATION

The TS-30 should be installed in a clean dry area. The area must be free of dust, oil, acid or other volatile vapors or V.O.C.'s (volatile organic compounds).

The TS-30 is an air-cooled system. Operating environment will affect overall ozone output, as higher temperatures will limit the capabilities of the Ozone Generator. As a general rule: *the highest the ozone output is achieved in a lower-temperature environment (80°F or less).*

Ambient temperature may not exceed 95°F or 85% Relative Humidity, at conditions beyond this the ozone output & longevity of the system will be significantly affected. If necessary, air conditioning and/or adequate ventilation should be utilized in the room in order to achieve maximum efficiency and longevity.

IMPORTANT: If the relative humidity could exceed 85%, a dehumidifier must be installed near the TS-30 to maintain optimum conditions. Any high quality dehumidifier may be obtained from your local Home Depot, Lowe's Home Improvement, or other supplier.

Without adequate ventilation in a confined space, oxygen levels may be reduced such that the Oxygen Concentrator will not operate efficiently. If oxygen levels are reduced the longevity of the Zeolite absorption material in the Oxygen Concentrator could be compromised resulting in reduced ozone output and possible damage to the Ozone Generator. In addition, inadequate ventilation will result in heat buildup & eventual overheating of the system.

In order to prevent oxygen reduction, or ozone buildup in a confined space (less than 2000 cubic feet): There should be at least 3 air changes per hour in the space whenever the TS-30 is installed in a space *smaller than 2000 cubic feet.*

In order to prevent excessive heat: Air conditioning or suitable ventilation should be used as required to maintain temperature not to exceed 95° F or humidity not to exceed 85% RH.

Optionally, it is also possible to vent the effluent from the Oxygen Concentrator outside a confined space and thereby prevent oxygen reduction in the space.

For assistance with venting the Oxygen Concentrator or if the room conditions are in question, contact Ozone Solutions at 712-439-6880 for assistance.

LOCATION & MOUNTING

Location

- **Weather:** Choose a location for the TS-30 that does not allow rain or condensation to contact the unit. *The TS-30 is not weather proof.* It must be operated indoors or under a roof in a non-condensing environment.
- **Mobile Units:** If the system is to be mounted in a mobile unit (such as a trailer or movable building), mechanical shock and vibration prevention measures should be taken to protect the TS-30 from damage during relocation of the mobile unit. Never subject the unit to any kind mechanical shock or vibration (including shipping) unless it is standing upright, or unless adequate measures have been taken to secure the Air Compressor (mounted inside the TS-30).

Positioning & Accessibility

- The TS-30 should be positioned in such a way that the front door can be fully opened for future maintenance.
- All controls and connections are located on the right-hand side of the enclosure; these must be fully accessible for operation.
- Located on the left-hand side and front door are a total of four (4) filtered air inlets. These must have a minimum 6 inch space free of obstruction for air movement, and must remain accessible for future maintenance.

Mounting

- **Wall Mounting:** The mounting tabs located on the top of the TS-30 are **NOT intended to support the weight** of the TS-30. A heavy-duty shelf or other means of support must be used to set the unit on, and then the mounting tabs on top may be used to secure the TS-30 to prevent tip-over or other movement. If necessary the leveling feet can be removed & the TS-30 may be secured at the bottom.
- **Floor Mounting:** The TS-30 may be set directly on the floor. In situations where there is no risk of danger from tip-over or movement due to vibration, the TS-30 may remain unsecured. If necessary the mounting tabs on top may be used to secure the TS-30 to prevent tip-over or other movement. Also the leveling feet can be removed & the TS-30 may be secured at the bottom.

CONNECTIONS

Electrical Power

The TS-30 is equipped with a power cord and can be plugged into a dedicated 120V/15A receptacle. In some locations, 20 Amp overcurrent protection may be required to allow for compressor startup.

Optional Electrical Control Connections

The TS-30 is equipped with terminals to allow connection of external switching; or external alarms or equipment. The TS-30 electrical control circuitry is located inside the enclosure in the upper right-hand corner. Drill holes as necessary for connection of electrical wiring. The terminals are labeled as follows:

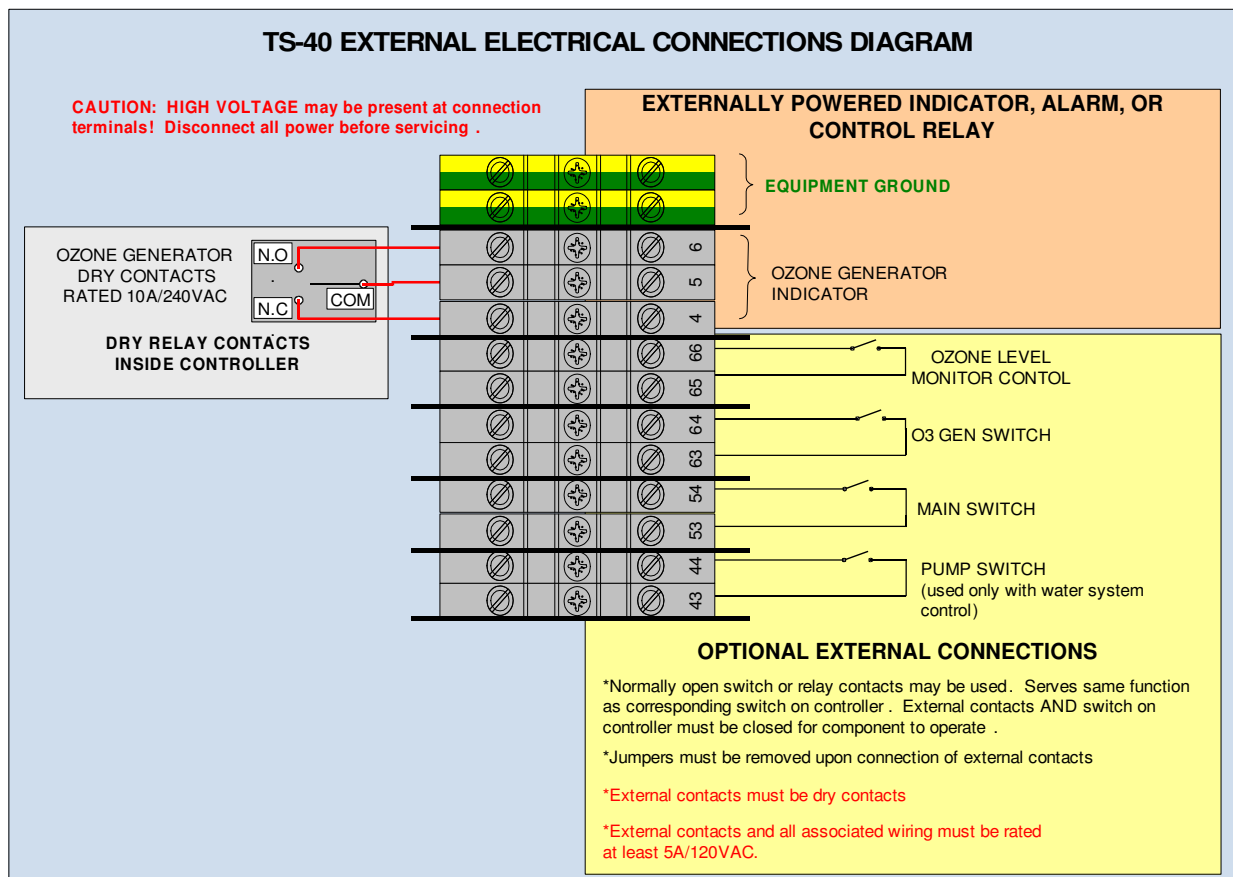

Ozone Out Connection

The OZONE OUT connection fitting is located on the right-hand side of the TS-30, just below the pressure gauges. It is a standard ¼ inch O.D. Stainless-Steel Compression fitting.

Connect any Ozone Resistant tubing with rigid walls for use in a compression fitting. Ensure that the compression fitting is properly tightened onto this fitting. When the compression fitting nut is bottomed out and finger tight turn the nut 1 ½ more turns. This is properly tightened.

WARNING: Use only PTFE Teflon, FEP Teflon, or other equivalent tubing approved for high concentration ozone. Use only Kynar, stainless steel, or other equivalent fittings approved for high concentration ozone. Using inadequate tubing or fittings will result in an ozone leak. Excessive ozone leakage may cause property damage, personal injury or death.

TS-30 Initial Startup Procedure

1. Set all switches on the TS-30 to the OFF position.
2. Ensure that all electrical connections & ozone tubing connections are complete.
3. Set the MAIN switch to RUN.
 - The Oxygen Concentrator inside the TS-30 will start.
 - AIR PRESSURE and O2 PRESSURE gauges on the TS-30 will indicate increasing pressures as the Oxygen Concentrator starts.
4. Check all external ozone tubing connections for possible leaks or restrictions.
5. Observe the O2 FLOW and O2 PRESSURE on the TS-30 while it is running. Ensure that any ancillary equipment connected to the TS-30 is also running. Pressure will decrease slightly (1-2 PSI) after the TS-30 has run for about 10 minutes, as the Air Compressor warms up. Adjust flow (via internal stainless steel needle valve) in order to maintain flow & pressure within the following range:
 - O2 PRESSURE 10 to 15 PSI
 - O2 FLOW 1 to 10 LPM

NOTE: Exact flow and pressure are not critical for initial setup purposes.

Make adjustments slowly, allowing oxygen (O2) pressure & flow to stabilize between adjustments. Oxygen (O2) pressure & flow will fluctuate slightly during normal operation, this is normal.

6. Once the oxygen flow is properly adjusted, the AIR PRESSURE gauge will continuously cycle between 15 and 40 PSI. This is due to cycling of the Oxygen Concentrator, and is normal expected operation.
7. Turn the O3 GEN switch on the TS-30 to ON. After a 2-3 second delay, the Ozone Generator will start and the O3 GEN light will illuminate.
8. Ozone is now being generated and exiting the OZONE OUT port at the flow & pressure indicated by the O2 FLOW meter and O2 PRESSURE gauge.

Operation

OXYGEN CONCENTRATOR (MAIN)

Operation

The Oxygen Concentrator uses ambient air to produce approximately 93% oxygen. It is of “molecular sieve bed” type construction and uses Zeolite absorption material with pressure swing absorption to remove the nitrogen from the air, leaving approximately 93% oxygen and approximately 7% other gases.

Oxygen Concentrator flow & pressure can be adjusted using the external Ozone Flow Control device. Optimum flow & pressure can be determined according to the “Ozone Generator Production” charts in the “Introduction” section of this manual. Generally, flow and pressure should be held within the following ranges:

- The **AIR PRESSURE** gauge indicates the pressure of air entering the molecular sieve beds. The air pressure will vary **between 15 and 40 PSI** as the sieve beds purge & regenerate in a constant cycle.
- The **O2 PRESSURE** gauge indicates the pressure of oxygen leaving the Concentrator. The O2 PRESSURE gauge will normally read much lower than the AIR PRESSURE and should be somewhat steady, reading between **8 and 20 PSI** under normal system operation.
- The **O2 FLOW** flowmeter indicates the flowrate of oxygen leaving the Oxygen Concentrator and passing through the Ozone Generator. The O2 FLOW should be held between **1 and 10 LPM**. The flowmeter is under pressure and displays “indicated” flow, not “actual” flow. O2 PRESSURE and the “indicated” O2 FLOW should be entered into the following formula to determine “actual” (corrected) flow:

$$(actualflow) = (indicatedflow) \times \sqrt{\frac{oxygenpressure + 14.7}{14.7}}$$

Normal Operation: Normally the TS-30 will operate as follows:

- **Air pressure:** 25-45 PSI
- **Oxygen Pressure:** 15 PSI
- **Oxygen Flow:** 7 LPM measured flow

NOTE: Lower than normal AIR PRESSURE or O2 PRESSURE is usually a sign of improper system setup (too much oxygen/ozone flow) or Air Compressor wear. The Oxygen Concentrator will rarely cause low pressure issues. For more information on low pressure issues see the “Maintenance & Troubleshooting” sections of this manual.

Control

The MAIN switch starts and stops the Oxygen Concentrator. When the Oxygen Concentrator starts, you will hear the Air Compressor start running and shortly thereafter you may hear the Oxygen Concentrator cycling as it purges effluent from the sieve beds.

NOTE: The Air Compressor will not start under pressure. Generally, if any amount of pressure is indicated on the AIR PRESSURE gauge the compressor will not start. The Air Compressor is equipped with an automatic thermal overload, and once the air pressure subsides and the motor is cool the compressor will automatically restart. This should take less than 1 minute, and is the normal expected operation of this equipment.

OZONE GENERATOR

Operation

The Ozone Generator is designed to produce ozone from oxygen under pressure. While maximum ozone production will be achieved at higher pressures and flows, the Oxygen Concentrator is limited to a given pressure at a given flow. Optimum flow & pressure can be determined according to the “Ozone Generator Production” charts in the “Introduction” section of this manual.

Control

The Ozone Generator (O3 GEN) will only start when the Oxygen Concentrator (MAIN) is ON. Turn the O3 GEN switch to ON to start the Ozone Generator. Ozone Generator can be turned off by turning the O3 GEN switch to OFF, or by turning the MAIN switch to OFF (shuts down TS-30 entirely).

O3 GEN Light

- **ON** – Ozone Generator is on
- **OFF** – Ozone Generator is off due to O3 GEN switch off or externally connected switch off.
- **FLASHING** – Ozone Generator is off due to “OZONE LEVEL MONITOR CONTROL” external connection off.

Variable Ozone Output 0-100%

The TS-30 is equipped with a Variable Ozone Output. The OZONE OUTPUT 0-100% knob on the control panel of the TS-30 will adjust the output of the Ozone Generator from 0 to 100% of the maximum ozone output. The control varies the power level to the ozone generation cell and only affects ozone concentration, it does not affect pressure or flow.

A setting of “0” on the knob will yield zero ozone output, while a setting of “10” will yield 100% of the Ozone Generator’s maximum output

TS-30 VENTILATION AND CONTROLS DIAGRAMS

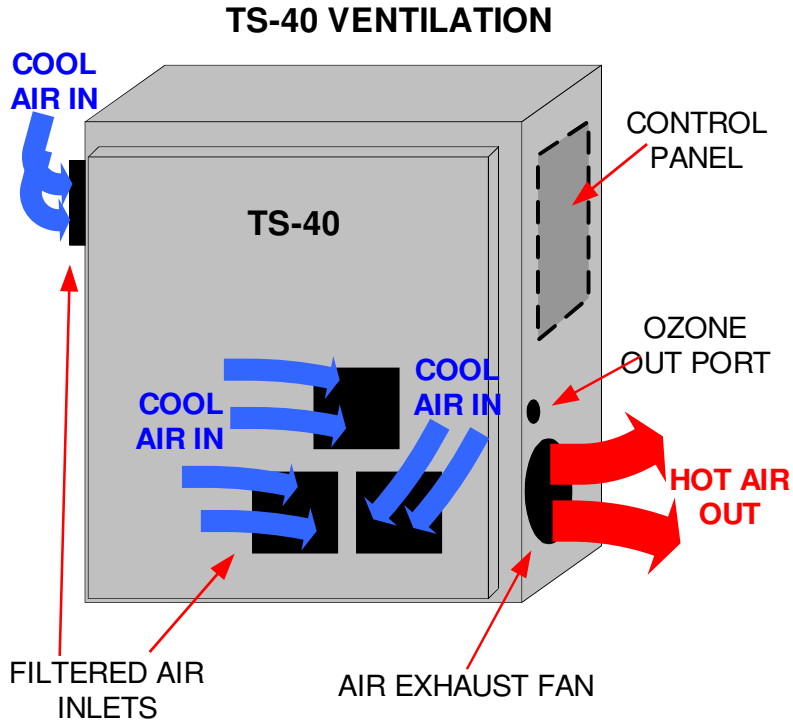

TS-40 CONTROLS

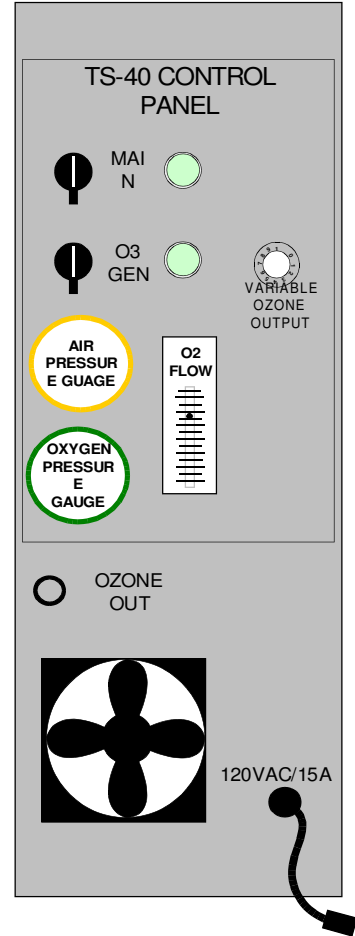

Maintenance Schedule

1. DAILY

- a. Check cooling fan on the side of the TS-30 (1 large fan) and inside on the Ozone Generator (2 fans) while the system is running. The fans should run whenever the Oxygen Concentrator is running.
- b. Check **AIR PRESSURE** gauge. Should read between **15-40 PSI** while system is running after startup. Low air pressure may be a sign incorrect oxygen flow settings, Air Compressor wear or massive air leaks. See also “low oxygen pressure...” below.
- c. Check **O2 PRESSURE** gauge. Should read between **8-20 PSI** while system is running after startup.

Low oxygen pressure is a sign of either:

1. Incorrect flow settings,
2. Air Compressor wear,
3. Massive oxygen leaks, or
4. Oxygen Concentrators sieve beds needing replacement.

2. **WEEKLY:** Check condition of cooling air inlet filters – 1 on left hand side of the TS-30 and 3 on the front door of the TS-30. Clean or replace as necessary when a layer of dirt is visible on the filter.
3. **EVERY 2 YEARS:** The Zeolite absorption material inside of the Oxygen Concentrator needs to be replaced every 2 years. The Zeolite absorption material (replacement sieve beds) can be obtained from Ozone Solutions. Adverse conditions may cause premature contamination of the Zeolite. Adverse conditions include:
 - Ambient **heat and humidity** levels above the recommended levels described in the “Installation” and “Specification” sections of this manual.
 - Extended periods of **low air pressure** while the system is running.
 - Extended periods of **oxygen flow above 10 LPM**.
4. **EVERY 8000 HOURS:** The Air Compressor will need to be rebuilt approximately every 8000 hours of use. If there are repeated AIR PRESSURE LOW or O2 PRESSURE LOW alarms and no other problems can be found, the Air Compressor may need rebuilding. Parts for this Maintenance can be obtained from Ozone Solutions.

Specifications

Maximum Ozone Production: 40 g/h at 10 LPM

Maximum Ozone Pressure/Flow: 15 PSI at 10 LPM flow

Environment:

Operating Temperature: 40°F to 95°F

Operating Humidity: 85% RH maximum, non-condensing (a dehumidifier operating in the TS-30 room is STRONGLY recommended)

Storage Temperature: -10°F to 150°F

Storage Humidity: non-condensing

Electrical Requirements:

Operating Voltage: 120

Full Load Amps: 8

Maximum Starting Current: 15 Amps

Power Consumption: 1,000 Watts

How to Contact Ozone Solutions

By mail:

Ozone Solutions, Inc.
451 Black Forest Rd
Hull, IA 51239

By telephone: (712) 439-6880

By fax: (712) 439-6733

Website: www.ozonesolutions.com

By e-mail: info@ozonesolutions.com