

aeroQUAL

Series 930 & 935
Transmitter/Controller

User Guide



Quick Start Guide

1. Unpack monitor and check supplied components are correct
2. Connect 24 VDC power supply to 5 pin connector pins
3. Configure monitor
 - Using computer:
 - Attach twisted pair cable to RS485 pins on 8-pin connector
 - Connect twisted pair to RS485 converter connected to computer
 - Load and run Configuration software
 - Turn on monitor
 - Configure monitor setpoints, ID etc.

 - Using R900:
 - Connect R900 to monitor and follow instructions in R900 manual
4. Connect Outputs
 - (A) If RS485 see "Operation as RS485 Transmitter"
 - (B) If 4-20 mA see "Operation as 4-20mA Controller"
 - (C) If Relay controller see "Operation as Relay Controller"
 - (D) If Display is fitted and the 4-20 mA loop is not being used see "Operating the LED Display if 4-20 mA loop is not being used"
5. Power on and allow monitor to warm up for a few hours to reach optimum operation.

Table of Contents

Quick Start Guide	1
Table of Contents	2
Foreword	3
Statement of Compliance	4
Warranty	5
For Your Safety	7
WARNING	7
Technical Support	7
Description	8
Components Supplied	8
Components not supplied but required	8
Connector Descriptions and Output Specifications	11
Operation.	12
Warming up	12
Standby	12
Operating the LED Display if 4-20 mA loop is not being used	13
Operation as a relay controller	14
Operation as a 4-20 mA transmitter	17
4-20 mA wiring diagram for Loop and Display (with opto-isolation)	17
420 mA wiring diagram for Loop and Display (no opto-isolation)	18
Operation as a RS485 Transmitter	19
Network Settings	19
Configuring the S930/S935	20
Connecting the R51: RS-485 to RS-232 Converter	22
Installing Moxa RS485 to USB Converter	23
Procedure	23
Care and Maintenance	26
Troubleshooting	27
Diagnostics	30
Appendix A	S930/S935 Specification and Photographs 31
Photographs	31
External view of S930 with display	32
Appendix B	Removing the sensor head 33
Appendix C	Sensor Head Specifications 34
Appendix D	Series 930 and 935 RS485 Protocol 35
APPENDIX E	Calibrating the LED display 37

Foreword

Copyright Aeroqual Limited. All rights reserved. Reproduction, transfer, distribution or storage of part or all of the contents of this document in any form without the prior written permission of Aeroqual Limited is prohibited.

"Aeroqual" and "Aeroqual Limited – Making the Invisible Visible" are registered trademarks of Aeroqual Limited. Other product and company names mentioned herein may also be trademarks or trade names.

Aeroqual operates a policy of continuous development. Aeroqual reserves the right to make changes and improvements to any of the products described in this document without prior notice.

Under no circumstances shall Aeroqual be responsible for any loss of data or income or any special, incidental, consequential or indirect damages howsoever caused.

The contents of this document are provided "as is". Except as required by applicable law, no warranties of any kind, either express or implied, including, but not limited to, the implied warranties of merchantability and fitness for a particular purpose, are made in relation to the accuracy, reliability or contents of this document.

Aeroqual reserves the right to revise this document or withdraw it at any time without prior notice. The availability of particular products may vary by region. Please check with the Aeroqual dealer nearest to you.

© Aeroqual Limited 2009. All rights reserved.

3.2.09



Aeroqual Limited

109 Valley Road, Mount Eden, Auckland, New Zealand

phone +64 9 623 3013

fax +64 9 623 3012

email technical@aeroqual.com

web www.aeroqual.com

Statement of Compliance

1. The Aeroqual Series 930/935 Transmitter/Controller complies with EN 50082 -1: 1997
2. The Aeroqual Series 930/935 Transmitter/Controller complies with EN 50081 -1: 1992
3. The Aeroqual Series 930/935 Transmitter/Controller comply with Part 15 of the FCC Rules. Operation is subject to the following two conditions:
 - (i) these devices may not cause harmful interference, and
 - (ii) these devices must accept any interference received, including interference that may cause undesired operation.

NOTE: This equipment has been tested and found to comply with the limits for a Class B digital device, pursuant to Part 15 of the FCC Rules.

Warranty

Thank you for purchasing this Aeroqual product. To get maximum use of the features of your new product we recommend that you follow a few simple steps:

Read the guidelines for safe and efficient use.

Read all the terms and conditions of your Aeroqual Warranty.

Save your original receipt. You will need it for warranty repair claims. Should your Aeroqual product need warranty service, you should return it to the dealer from whom it was purchased or contact Aeroqual.

Our Warranty

Aeroqual warrants this product to be free from defects in material and workmanship at the time of its original purchase by a consumer, and for a subsequent period as stated in the following table:

Products	Warranty Period
Series 930/935 Transmitter/Controller	One year from the date of purchase
Sensor heads – all gases	Six months from the date of purchase
Other Accessories	One year from the date of purchase

This warranty is expressly limited to the original owner who purchases the equipment directly from Aeroqual or from an authorized Aeroqual dealer.

What we will do

If, during the warranty period, this product fails to operate under normal use and service, due to improper materials or workmanship, Aeroqual subsidiaries, authorized distributors or authorized service partners will, at their option, either repair or replace

the product in accordance with the terms and conditions stipulated herein.

Conditions

The warranty is valid only if the original receipt issued to the original purchaser by the dealer, specifying the date of purchase, is presented with the product to be repaired or replaced. Aeroqual reserves the right to refuse warranty service if this information has been removed or changed after the original purchase of the product from the dealer.

If Aeroqual repairs or replaces the product, the repaired or replaced product shall be warranted for the remaining time of the original warranty period or for ninety (90) days from the date of repair, whichever is longer. Repair or replacement may be via functionally equivalent reconditioned units. Replaced faulty parts or components will become the property of Aeroqual.

This warranty does not cover any failure of the product due to normal wear and tear, damage, misuse, including but not limited to use in any other than the normal and customary manner, in accordance with Aeroqual's user guide for use, faulty installation, calibration and maintenance of the product, accident, modification or adjustment, events beyond human control, improper ventilation and damage resulting from liquid or corrosion.

This warranty does not cover product failures due to repairs, modifications or improper service performed by a non-Aeroqual authorized service workshop or opening of the product by non-Aeroqual authorized persons.

The warranty does not cover product failures which have been caused by use of non-Aeroqual original accessories.

Tampering with any part of the product will void the warranty.

Damage to the sensors can occur through exposure to certain sensor poisons such as silicones, tetraethyl lead, paints and adhesives. Use of Aeroqual sensors in these environments containing these materials may (at the discretion of Aeroqual) void the warranty on the sensor head. Exposure to gas concentrations outside of the design range of a specific Aeroqual sensor head can adversely affect the calibration of that sensor head and will also void this warranty as it applies to the replacement of sensor heads.

Aeroqual makes no other express warranties, whether written or oral, other than contained within this printed limited warranty. To the fullest extent allowable by law all warranties implied by law, including without limitation the implied warranties of merchantability and fitness for a particular purpose, are expressly excluded, and in no event shall Aeroqual be liable for incidental or consequential damages of any nature whatsoever, however they arise, from the purchase or use of the product, and including but not limited to lost profits or business loss.

Some countries restrict or do not allow the exclusion or limitation of incidental or consequential damage, or limitation of the duration of implied warranties, so the preceding limitations or exclusions may not apply to you. This warranty gives you specific legal rights, and you may also have other rights, which may vary from coun-

try to country.

For Your Safety

Read these simple guidelines. Ignoring these guidelines may be hazardous.

USE SENSIBLY

Use only as per this user guide.

USE AEROQUAL APPROVED SERVICE

Only approved service personnel must work on this product.

ACCESSORIES

Use only approved accessories. Do not connect incompatible products.

CONNECTING TO OTHER DEVICES

When connecting to any other device, read the appropriate user guide for detailed safety instructions. Do not connect incompatible products.

HAZARDOUS ENVIRONMENTS

Do not use the Gas Sensors in or near volatile fuel or chemicals.

HEALTH AND SAFETY IN THE WORKPLACE

The Aeroqual Series 930/935 Transmitter/Controller and Sensor Heads are used to monitor ambient gas concentrations. Aeroqual does not guarantee user safety. In hazardous environments, an appropriate Health and Safety plan should be in place.

WARNING

Do not expose the monitor to gas concentrations outside the range of the specific sensor head.

Do not switch the monitor on before reading the User Guide.

Do not open the product enclosure or attempt to remove the sensor head while the unit is powered up.

Technical Support

Technical information, service and spare parts are available through your distributor. In addition, world wide technical support is available from Aeroqual Ltd. Please contact:

Aeroqual Limited
109 Valley Road, Mt Eden, Auckland 1024, New Zealand
Phone: +64 9 623 3013
Fax: +64 9 623 3012
Email: technical@aeroqual.com

Description

The Aeroqual **Series 930 Transmitter / Controller** is designed to measure and control gas concentrations, and to communicate to a variety of hardware systems. The **Series 935** also measures Temperature and Relative Humidity and transmits this on the RS485 output.

The Series 930/935 Transmitter /Controller can operate as a relay controller with user controlled setpoints, as 4-20 mA gas transmitter and it can communicate via RS485 on a network. Series 900 PC Networking & Data logging Software for connecting a RS485 network of S930/S935 monitors to a computer is available as an option. Please contact your distributor if you require this.

The S930/S935 monitors can be supplied with or without a LED display. If you have ordered a monitor with display the 4-20 mA loop will need to be powered in order for the display to function correctly. If the loop is not powered then the display will typically display -.125.

Components Supplied

- Series 930 or 935 base unit (transmitter / controller)
- Gas Sensor Head (installed)
- Temperature and Relative Humidity Sensor (S935 only)
- User guide & Configuration Software CD
- Enclosure mounting brackets
- 2 x Male cord connectors (8-pin & 5-pin)

Please check that all these components have been supplied and contact your dealer or Aeroqual on email at: sales@aeroqual.com if any of the components are missing.

Components not supplied but required

- 24VDC 1A power supply
- RS485/RS232 converter or RS485/USB converter
- PC for configuring the monitor.
- Multi-strand twisted pair cables for connections

Digital Communication Systems (Multi-Sensor Networks)

The Series 930 and 935 are designed to operate as part of a network system with computer-based systems or PLC controllers.

A full range of measurement and control functionality is offered for digital systems.

Each unit can be given a unique ID (required for digital networking systems)

The set-up for digital network communications requires termination resistors on the RS485 communication lines to be correctly set.

Section 11, See operation as a RS485 transmitter.

Gas Measurement Guidelines

The following information is presented to help users operate their **Aeroqual S930/935 Transmitter/Controller** in the most effective and efficient manner.

Installation Guide

The **S930/935** should be installed at a location that is free from contaminants that might affect the performance of the sensor head. Please contact technical@aeroqual.com for assistance with specific chemicals that you believe may adversely affect the supplied sensor. In general the S930/935 should **never** be exposed to:

- steam, fumes, water or chemical spray
- aggressive solvents
- high condensing humidity
- cooking vapors/aromas
- paint fumes
- high levels of dust

Permanent Controller Placement

- The **S930/935** has been designed to measure the ambient gas concentration.
- For indoor local area monitoring attach the controller to an inert surface.
- For leak detection mount the unit as close as possible to potential gas leaks.
- Ensure that the controller is protected from excessive water splashing, dust, vibration, excessive heat or cold, excessive swings in humidity and gas concentrations outside the range of the specific sensor head.

Warm up

- It is recommended that the sensor head for the Series 930/935 transmitter/controller is run for up to 24 hours prior to use as a control or alarm function if it has been switched off for more than 7 days. This will remove any surface contamination on the sensor that may influence the accuracy of the sensor.

Calibration

- The sensor head is calibrated prior to delivery.
- Environmental conditions such as dust, high humidity, vibration, chemicals and heat or cold as well as high concentrations of gases may degrade the sensor performance and shorten the sensor life. Please ask your local dealer or contact Aeroqual at technical@aeroqual.com about your application if you are in doubt.

Connector Descriptions and Output Specifications

The connector designations are shown in the diagram and photograph below. Their descriptions and use are detailed in the following table.

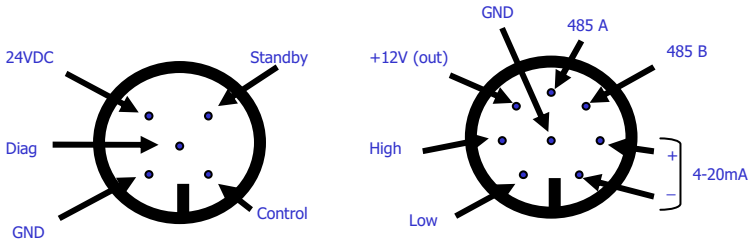

5 pin and 8 pin connectors as viewed from the outside of the box	
5 pin connector	
Power:	Connect input power (16-28VDC)
DIAG	This is set to GND when sensor fails, else floating. The output is an open collector current sink. The maximum rating of the transistor output is 24VDC at 150mA.
GND	Ground
CNTRL	The output is an open collector current sink. The maximum rating of the transistor output is 24VDC at 150mA. Should you connect a relay coil or any other inductive load to the transistor outputs, a back EMF suppression diode must be fitted across the load.
STDBY	If set to GND externally it puts the sensor head into Standby mode and the S930/935 into Sleep mode. If set to GND again it will return to normal operation.
8 pin connector	
LoALM	This is set to GND when low alarm point is reached, else floating. Use the Configuration Program to setup. The output is an open collector current sink. The maximum rating of the transistor output is 24VDC at 150mA. Should you connect a relay coil or any other inductive load to the transistor outputs, a back EMF suppression diode must be fitted across the load.
HiALM	This is set to GND when high alarm point is reached, else floating. Use the Configuration Program to setup. The output is an open collector current sink. The maximum rating of the transistor output is 24VDC at 150mA. Should you connect a relay coil or any other inductive load to the transistor outputs, a back EMF suppression diode must be fitted across the load.
12 V (out)	12VDC output from the S930 which can be used to power the 4-20 mA loop if opto-isolation is not required. However if a display is fitted and the loop output is required it is recommended that an external power supply be used otherwise problems associated with high loop impedance and/or ground loops may arise.
GND	Ground
RS485 A RS485 B	Communication lines. These are used to communicate with and configure the S930/935.
+ - (4-20mA loop)	4-20 ma loop connection. The output is opto-isolated and designed to be externally powered with a voltage range of 12-24V. Maximum voltage is 30 VDC. It may be powered using the 12 VDC output pin on the connector but this will remove the opto-isolation. The maximum total loop resistance should be 100 ohms at 12V and 500 ohms at 24V. The output is linearly proportional to concentration. The default concentration scale is dependent on the concentration range of the sensor head type. The concentration scale can be defined by the user using the Configuration Program. If the sensor fails the output will be 20 mA.

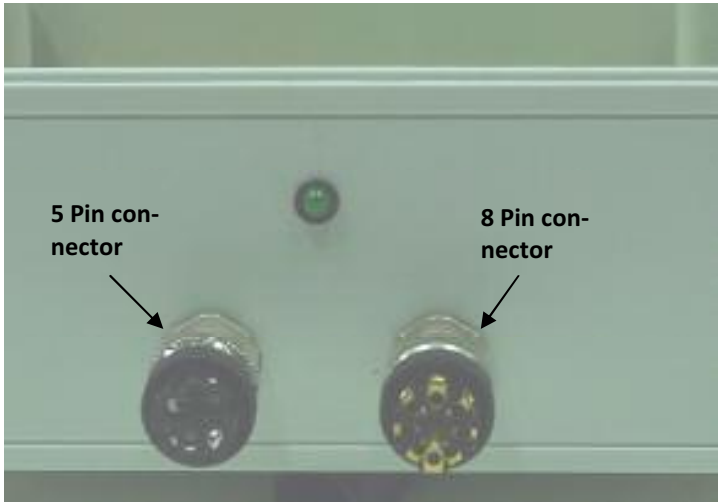

Photograph of S930 connectors

Operation.

Warming up

Please warm up the S930/S935 for a few hours after it is first unpacked to enable it to achieve maximum performance.

Standby

If the environment from which the monitor is sampling is subject to liquid sprays or misting (eg cleaning or decontamination regimes) it is recommended that the unit be put into STBY mode which turns off the internal pump and stops contaminants entering the unit.

Operating the LED Display if 4-20 mA loop is not being used

LED display models are designed to operate in conjunction with the 4-20mA circuit. If the 4-20mA output is not being used the display can still be enabled by connecting two wire loops (see diagram below) on the 8-pin connector between,

- a) the positive 4-20mA pin to the +12v output pin and
- b) the negative 4-20mA pin to GND (ground).

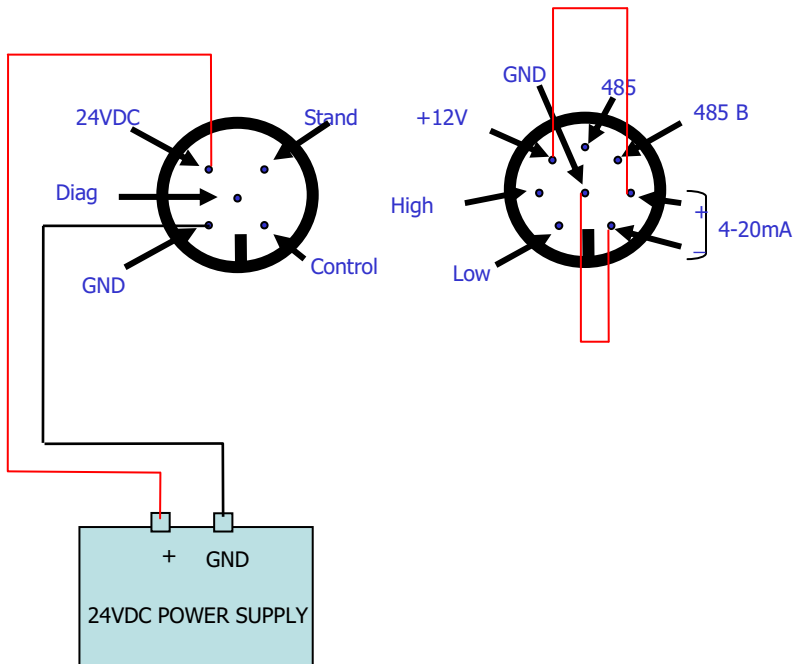

Operation as a relay controller

The S930/S935 can be used as a simple relay controller using the alarm or control outputs which are open collector current sinks. They are set to ground when activated according to their setpoints. The setpoints can be configured by computer using the supplied Configuration program or using a R900 programmer (see Aeroqual for more information). It is recommended that the DIAG output is always used to alert a sensor fault condition.

Procedure

1. Connect 24 V DC power supply to 5-pin connector
2. Connect alert relay/alarm to DIAG output on 5-pin connector if required
3. Connect relay ground toggle to STDBY pin on 5-pin connector if required.
4. Connect control relay to CNTL output on 5-pin connector if required.
5. Connect relays to LoALM and/or HiALM alarm outputs on 8-pin connector if required
6. Power on and test response.

The description and operation of the outputs are given below:

DIAG

This output is designed to enable detection of sensor faults. This is normally floating but is set to GND when the sensor fails. Thus it can be considered a "switch" which is closed when the sensor fails. This can be used to activate an alarm or relay and can also be monitored with a PLC. The output is an open collector current sink. The maximum rating of the transistor output is 24VDC at 150mA.

LoALM

This is set to GND when low alarm is activated. It is floating at other times. Use the Configuration Program to set the Lo alarm set point. The output can be used to drive an alarm relay or similar. The alarm can be set to trigger above or below the set point using the configuration software. The output is an open collector current sink. The maximum rating of the transistor output is 24VDC at 150mA. Should you connect a relay coil or any other inductive load to the transistor outputs, a back EMF suppression diode must be fitted across the load.

HiALM

This is set to GND when high alarm is activated. It is floating at other times. Use the Configuration Program to set the Hi alarm set point. The output can be used to drive an alarm relay or similar. The output is an open collector current sink. The maximum rating of the transistor output is 24VDC at 150mA. Should you connect a relay coil or any other inductive load to the transistor outputs, a back EMF suppression diode must be fitted across the load.

CNTRL

This is set to GND when the gas concentration is rising in the range from below Control low set point to the Control high set point at which stage, it is set to floating. It remains floating until the concentration falls below the Control low set point at which point, it is reset to ground. Use the Configuration Program to set the Control set points. This output can be used to control, for example, a gas generator or vent in a process operation. The output is an open collector current sink. The maximum rating of the transistor output is 24VDC at 150mA. Should you connect a relay coil or any other inductive load to the transistor outputs, a back EMF suppression diode must be fitted across the load.

STBY

STBY is a hardware toggle switch. If it is briefly pulsed (about 50ms) to GND it puts the sensor head into Standby mode and the S930 into Sleep mode. If pulsed again to GND it will return to normal operation. This can be used to protect the sensor during process room cleaning and/or to reduce power and extend sensor life when the sensor is not needed.

Operation as a 4-20 mA transmitter

The Series 930/935 can be connected to a PLC or current sensing device via the 4-20 mA output to provide concentration information. The output is linearly proportional to concentration. The full scale (20 mA) value is factory set but can also be user configured with the Configuration software supplied. If the sensor fails the output will be 20 mA. It is also recommended that the DIAG (diagnostic) output be used to monitor for fault conditions.

The 4-20 mA output loop is opto-isolated from the Series 930/935 unit and it is recommended that it be powered by a separate power supply with a voltage in the range 12-24 V applied with the correct polarity as labeled. This will produce the most reliable connection method. If opto-isolation is not important then the 4-20 mA loop may be powered by the same power supply as the unit.

LED display models are designed to operate in conjunction with the 4-20mA circuit and the loop needs to be powered correctly for the display to function correctly.

Procedure

1. Connect the 4-20 mA loop on the 8-pin connector to the power supply and current measuring device (eg PLC) ensuring the polarity is correct. Please refer to the diagrams below.

*****Caution: if the polarity is incorrect the 4-20 mA output may be permanently damaged *****

2. Power on the S930/935 and PLC
3. Check the PLC or current sensing device to ensure data is present.

4-20 mA wiring diagram for Loop and Display (with opto-isolation)

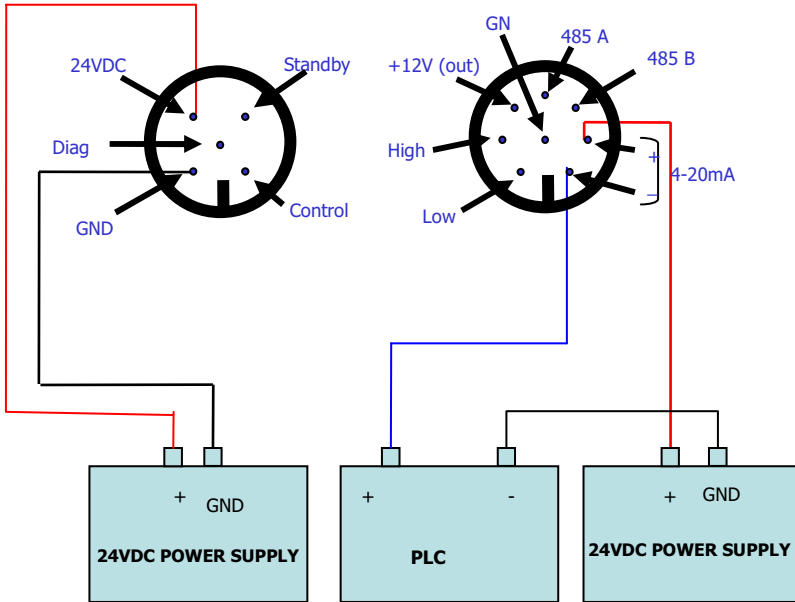

4-20 mA wiring diagram for Loop and Display (no opto-isolation)

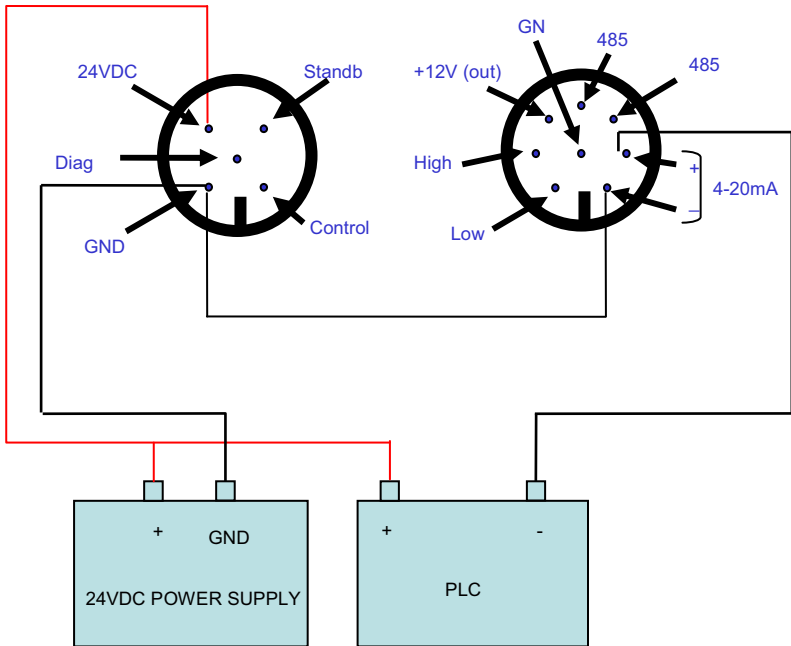

Operation as a RS485 Transmitter

The Series 930/935 unit can communicate over a RS485 bus. Each monitor has an ID which can be user set via the Configuration software and up to 255 units networked together. Aeroqual supplies a Configuration program to configure the S930/S935 over the RS485 - please refer to the section in the manual to learn how to do this. Aeroqual can also supply Networking software to set up a RS485 network of S930/S935 units linked to a computer. Alternatively the user can write their own PLC or computer software to communicate with the S930/S935 based on the protocol detailed in Appendix C. Please read the section on RS485 Network Settings below to learn about setting up a network of S930/S935.

Connecting via RS485

1. Connect a 24 vDC power supply to the power input on the 5-pin connector
2. Use twisted pair cable to connect the RS485 lines on the 8-pin connector to the RS485 hub, bus or converter .
3. Power on the monitor and run the communication software (either Aeroqual Networking Software or your own software) on your computer or PLC

Network Settings

If the S930/S935 is to be used as part of a "daisy chained" RS485 network a number of settings need to be adjusted.

1. Jumper settings

The termination resistors need to be set correctly to ensure the network communication is stable. The jumpers JP1, JP2, JP3 are to install termination resistors on the RS485 communication lines. Remove the jumpers J1, J2, J3 for all S930/935 units in a chain except the last S930/935 unit in the network chain. If there is only one unit then set the jumpers in place.

To access these jumpers remove the sensor head and then remove the four screws on the mounting plate. The PC board (as shown below), is located on the under-side of the fixing plate.

2. ID Settings

The ID of the monitors on the network need to be unique so they can be distinguished on the RS485 network. The ID of the unit is factory set as 1 and therefore it will need to be changed. Use the Configuration program to change the IDs (see the section on Configuring the monitors, p20).

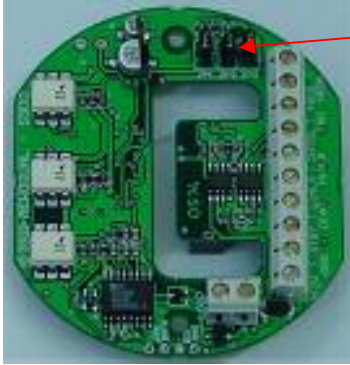

Jumpers

Configuring the S930/S935

The Series 930/935 alarm and 4-20 mA output scale settings can be modified using a computer and the supplied S900 Configuration Program or using a R900 purpose made hand held communication tool. For further details on the R900 contact your supplier or Aeroqual Limited (technical@aeroqual.com).

To configure the S930/S935 by computer you will need an RS232/RS485 or USB/RS485 converter. There are many RS232/RS485 converters on the market. Only certain brands will function well with Aeroqual's products. Aeroqual can supply a converter (R51) suitable for configuring a single monitor (it is not suitable for a S930 network). Converters which have been tested by Aeroqual can be purchased from Aeroqual or it's distributors, or contact Aeroqual for recommended brands on technical@aeroqual.com.

Computer requirements

- CD-ROM Drive
- RS232 port
- Windows OS version 95 or later.
- 45 Mb of spare hard drive space

Additional components required:

- 24V power supply
- RS232/RS485 or USB/RS485 converter
- RS485 wired S930/S935

Connecting the R51: RS-485 to RS-232 Converter

Connect to
PC serial
COM port or
USB via R52



TD(A) connect to
RS485B

TD(B) connect to
RS485A

RS-485 to RS-232 Converter to Series
930/930

TD(A) connect to RS485B

TD(B) connect to RS485A

GND – not required

GND – not required

+12V – not required

Using a USB to RS485 converter



Recommended supplier: Moxa, www.moxa.com

Note: Aeroqual S900 series monitors communicate via 2 wire RS485 so the converter must be configured to RS485 2W using software supplied with the converter.

Installation instructions for version 1.5.0.0 of the Moxa UPort1150 driver.

Configure a Moxa UPort 1150 for RS485-2 wire mode as follows:

1. Install software from the CD provided with Moxa UPort 1150
2. Attach Moxa UPort 1150 USB device to USB port
3. Once the drivers have been installed for the device, open up the device manager (found under control panel/system/device manager (Windows Vista), OR Control panel/system/hardware/device manager (Windows XP)
4. Right-click on the UPort 1150 item and select properties
5. Expand the "Multi-port serial adapters" item
6. Click on the "Ports Configuration" tab
7. Select the appropriate COM port
8. Click on the button labeled "Port Setting"
9. Under heading "Interface", select the "RS-485 2W" entry from the drop down list
10. Click OK in this window and in the original window opened from the Device Manager in step 5

Procedure for S930 / S935 operation

- 1) Plug in and install the USB or RS232 to RS485 converter into your computer.
- 2) Connect the Series 930/935 RS485 port leads to the converter
- 3) Install the Aeroqual Series 930/935 Configuration Program on the computer if not already installed.
- 4) Power up the Series 930/935 unit.
- 5) Run the Aeroqual Series 930/935 Configuration Program.
- 6) Select Unit by entering the ID of the S930/935 you wish to modify (and click on "Download" to download the unit's current values).
- 7) Modify settings
- 8) Click Upload to upload the settings to the S930/935
- 9) Click Exit
- 10) Power down the S930/935 and install.

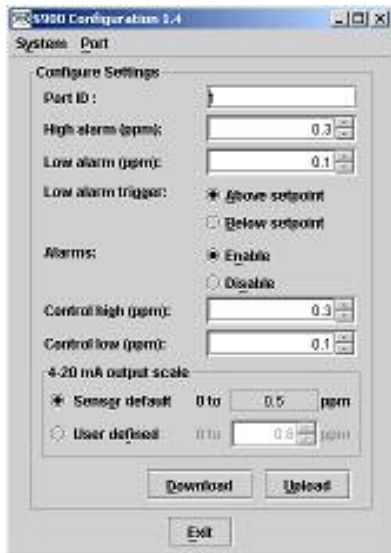

Port ID

Click on "Port" menu and select "Change port ID" to change ID to your requirement in the range 1 to 255.

Caution: if you are setting up a network please ensure each unit has a unique ID otherwise there will be conflicts and data loss.

Alarms

High alarm and low alarm setpoints can be set by clicking on the appropriate window and entering the required activation setpoint. Please note: High alarm setpoint must be greater than low alarm setpoint.

The low alarm trigger determines whether low alarm is activated by being above or below the setpoint. Click mouse on the button to select. The Alarms can be enabled or disabled by clicking on the button alongside Enable or Disable, respectively.

Control

The control output is triggered according to the band set by the Control high and Control low values. Control high must be greater than Control low. The action of this output is designed to enable control of an ozone generator. The Control output will be "on" when the concentration is rising in the range from below Control low until it hits Control high when it turns off. It remains off until the concentration falls below Control low.

4-20 mA output scale

This sets the gas concentration scale that corresponds to 4 -20 mA. Each sensor head type has a default setting but the user can modify this by clicking the user define button and entering the required value that corresponds to 20 mA.

(NOTE: The LED display is calibrated for the default settings only and will not operate correctly if the default range is altered – if you are in any way uncertain of this, please seek technical assistance from Aeroqual.)

Upload

Clicking this button uploads the settings to the S930/935.

Download

Clicking this button downloads the settings from the S930 or S935. Use this function to check the settings are correct.

Care and Maintenance

Your Aeroqual S930/935 is a product of superior design and quality and should be treated with care. When using your S930/935:

Keep it and all its parts and accessories out of the reach of small children.

Keep it dry. Avoid water and/or condensation as humidity and liquids containing minerals may corrode electronic circuits.

Do not use or store in dusty, dirty areas.

Do not expose sensor heads to higher levels of gas than its designed range.

Only operate within its specified temperature range. Avoid sudden changes in temperature will cause condensation that may damage the electronic components.

Do not drop, knock or shake as this could lead to internal damage.

Do not use harsh chemicals, cleaning solvents or strong detergents for cleaning. Wipe with a soft cloth slightly dampened with a mild soap-and-water solution.

Troubleshooting

Fault Description	Possible cause	Remedy
No power	Lead connection broken	Reconnect power lead
	Power supply failure	Replace 24V power supply
	S930/935 damaged	Replace unit
RS485 communications unstable	RS485/RS232 adaptor faulty	Reconfigure/replace adaptor
	Connections broken	Reconnect leads
	ID incorrect	Check ID
	Noise on cable	use shielded twisted pair cable
	Sensor head not fitted correctly	Insert head correctly
4-20 mA output failure	30V input exceeded	Replace S930/935
Network unstable	ID conflict	Modify IDs so that no S930/935 units share the same ID
	Noise on leads	use shielded twisted pair cable
	Jumpers set incorrectly	Set jumpers correctly
	S930/935 units too close together	The leads between S930/935 units should be a minimum of 30 cm in length.
Display shows -1	over-range (>20 mA) reverse loop current	Loop polarity is incorrect. Reverse this. Incorrect loop polarity can cause irreversible damage to the S930/S930. Reduce loop current.
Display shows 1	over-range loop current (>20 mA)	Reduce loop current
Display shows -.125	4-20 mA Loop not powered	Power loop. The display requires the loop to be powered to read correctly

Display oscillates between min and max	Sensor head not fitted correctly	Insert sensor head correctly
Sensor failure when new sensor	Insufficient warm-up	Run the sensor for 24-48 hours
	Air contaminated	Move the sensor to cleaner environment and check reading
	Sensor damaged	Replace sensor
Sensor showing high baseline reading under zero gas conditions	Background gas level higher than normal	Move sensor to clean air and recheck baseline
	Interferent gas present	Move sensor to clean air and recheck baseline
	Sensor zero drift	Re zero sensor in a clean, stable background
	Sensor damaged	Replace sensor
	Flow incorrect	Measure sample flow and compare with specification. If incorrect check for leaks and/or replace pump.
Sensor showing higher than expected reading in the presence of sensor gas	Zero calibration incorrect	Zero calibrate sensor
	Span calibration incorrect	Span calibrate sensor
	Sensor correct	Check calibration of gas generator.
	Interferent gas present	Move sensor to clean air and check reading upon exposure to known gas concentration
	Sensor calibration lost	Replace /refurbish sensor
	Flow incorrect	Measure sample flow and compare with specification. If incorrect check for leaks and/or replace pump.

Sensor output noisy	S930/935 power supply unregulated	Install regulated power supply
	Local air flow too high	Reduce air flow
	Environmental conditions fluctuating	Reduce fluctuations
	Pump not working correctly	Replace pump.
Sensor showing lower than expected reading in the presence of sensor gas	Zero calibration incorrect	Zero calibrate sensor
	Span calibration incorrect	Span calibrate sensor
	Sensor correct	Check calibration of gas generator.
	Sensor inlet contaminated	Clean sensor inlet filter and mesh
	Interferent gas present	Move sensor to clean air and check reading upon exposure to known gas concentration
	Gas reactive and decomposing before detection	Move the monitor closer to the source of the gas
	Sensor calibration lost	Replace /refurbish sensor
	Flow incorrect	Measure sample flow and compare with specification. If incorrect check for leaks and/or replace pump.

Diagnostics

The S930/935 has inbuilt diagnostics to detect sensor faults. If the sensor fails it can be easily replaced by simply removing and installing a new one (see sensor manual for details). The failed sensor can be sent back to Aeroqual for refurbishment or disposal.

Table of fault condition diagnostics

Fault description	DIAG output	4-20 mA output	RS485 output
No fault	floating	valid gas reading	valid gas reading Status1 = 0x00
Sensor failed fault	GND	20 mA	last valid gas reading Status1=0x01
Sensor aging fault	GND	20 mA	last valid gas reading Status1=0x02
Sensor not fitted correctly	GND	Oscillates between 4 and 20 mA	no reply

Appendix A Photographs

S930/S935 Specification and

Power Outputs	24VDC, 500mA (range 22-26 VDC) 4-20 mA (opto-isolated) 12-24 V (30 VDC max) maximum loop resistance = 500 Ω at 24V.
Inputs Jumpers	4 x Relay outputs (Hi alarm, Low alarm, Control, Diagnostics) RS485 (two wire) Standby toggle J1, J2, J3 termination resistors for RS485 network
Ingress Protection Connectors ID	IP40 equivalent Screw 1 (Default) User configurable from 1 to 255 Aeroqual proprietary protocol (see Appendix C)
RS485 protocol	
Enclosure Mounting	Polycarbonate Screw fix
Operating temperature	-5°C and +40°C (23°F and 120°F)
Operating relative humidity	5 to 95% non-condensating
Enclosure size	180W x 110H x 90D (mm); (WxHxD)
Sample Flow rate	0.2 +/-0.1 LPM

Photographs



Internal view of S930 with display

The S935 has a Temperature and RH probe located here



Height = 90 mm

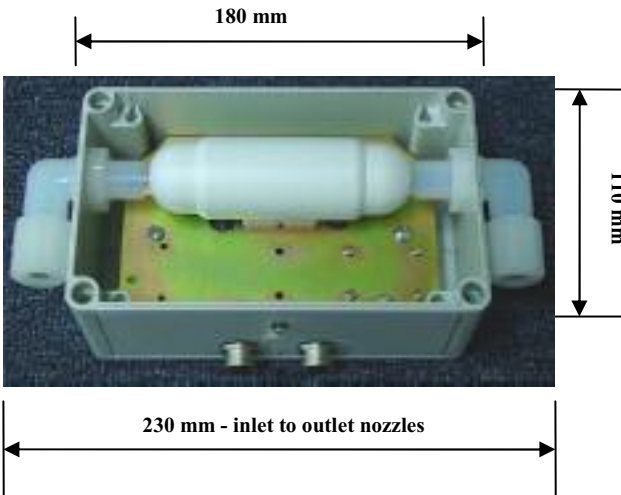

180 mm

110 mm

230 mm - inlet to outlet nozzles

Appendix B: Removing and Replacing the Sensor Head

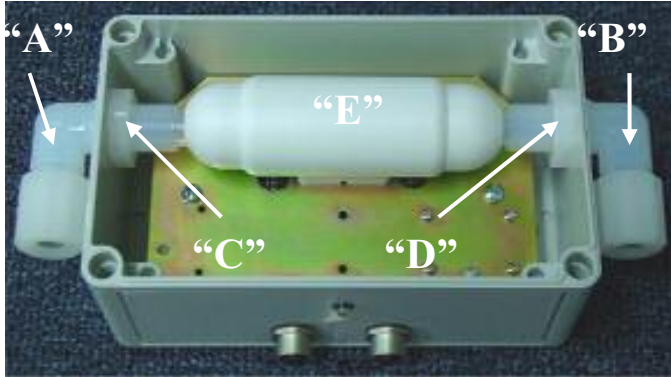

Undo the four lid screws, remove lid and view the interior of the enclosure as shown above.

Unscrew and remove the inlet & outlet nozzles "A" & "B" as well as the corresponding lock-nuts "C" & "D".

Remove the sensor head "E".

Now replace the sensor head (keyed to fit one way only) and reposition nozzles "A" & "B".

Finally, tighten lock-nuts "C" & "D".

Appendix C

Sensor Head Specifications

Sensor	Calibrated Range	Maximum Exposure	LDL	Accuracy	Resolution	Re-sponse Time (T ₉₀)	Operational Range		4-20mA output scale
							Temp.	RH ⁶	
Ammonia 0 - 100 ppm	0 - 100	200	0.5 ppm	<±5 ppm 0-100 ppm	0.1 ppm	<60 s	-20°C to 40°C	5 to 95%	100ppm
Ammonia (leak) 0 - 1000 ppm	0 - 1000	2000	2 ppm	<±15%	1 ppm	<60 s	-20°C to 40°C	5 to 95%	1000ppm
Carbon monoxide 0 - 100 ppm	0 - 100	200	0.5 ppm	<±5 ppm	0.1 ppm	<150 s	0°C to 40°C	5 to 95%	100ppm
Carbon monoxide 0 - 1000 ppm	0 - 1000	2000	1 ppm	<±10%	1 ppm	<150 s	0°C to 40°C	5 to 95%	1000ppm
Carbon dioxide 0 - 2000 ppm	0 - 2000	NA	-	<± (40 ppm + 3%)	10 ppm	<60 s	0 to 40°C	5 to 95%	2000ppm
Carbon dioxide 0 - 5000 ppm	0 - 5000	NA	-	<± (150 ppm + 5%)	10 ppm	<60 s	0 to 40°C	5 to 95%	5000ppm
Carbon dioxide 0 - 5.00%	0 - 5.00%	NA	-	<± 5%	0.01%	<60 s	0 to 40°C	5 to 95%	5%
Hydrogen 0 - 5000 ppm ¹	0 - 5000	20000	5 ppm	<±10%	1 ppm	<90 s	-20°C to 40°C	5 to 95%	5000ppm
Hydrogen sulphide 0 - 10 ppm ¹	0 - 10	25	10 ppb	<±0.5 ppm	0.01 ppm	<60 s	-20°C to 40°C	5 to 95%	10ppm
Hydrogen sulphide 0 - 50 ppm	0 - 50	100	0.05 ppm	<±1 ppm 0-10 ppm <±2 ppm 10-50 ppm	0.1 ppm	<60 s	-20°C to 40°C	5 to 95%	50ppm
Methane 0 - 10000 ppm	0 - 9999	10000	-	<±15%	1 ppm	<60 s	0°C to 40°C	30 to 80%	10000ppm
Ozone 0 - 0.150 ppm	0 - 0.150	0.250	1 ppb	<±0.005 ppm	0.001 ppm	<70 s	-5°C to 40°C	5 to 95%	0.5ppm
Ozone 0 - 0.5 ppm	0 - 0.500	1	1 ppb	<±0.008 ppm 0-0.1 ppm <±10% 0.1-0.5 ppm	0.001 ppm	<60 s	-5°C to 40°C	5 to 95%	0.5ppm
Ozone 0.5 - 20 ppm ²	0.5 - 20	25	10 ppb	<±10% 0.5-2 ppm <±15% 2-20 ppm	0.01 ppm	<35 s	-5°C to 40°C	5 to 95%	20ppm
Nitrogen dioxide 0 - 0.2 ppm	0 - 0.200	0.500	1 ppb	<±0.01 ppm 0-0.1 ppm <±10% 0.1-0.2 ppm	0.001 ppm	<180 s	0°C to 40°C	30 to 70%	0.2ppm
NMHC ^{3,4} 0 - 25 ppm	0 - 25	50	0.1 ppm	<±10% 0.1-25 ppm	0.1 ppm	<60 s	-20°C to 40°C	5 to 95%	25ppm

NMHC ^{3,4} 0 - 25 ppm	0 - 25	50	0.1 ppm	<±10% 0.1-25 ppm	0.1 ppm	<60 s	-20°C to 40°C	5 to 95%	25ppm
Perchloroethylene 0 - 200 ppm	0 - 200	250	1 ppm	<±5 ppm 0-50 ppm <±10% 50-200 ppm	1 ppm	<5 s (T ₅₀)	0°C to 40°C	30 to 80%	200ppm
Sulphur dioxide 0 - 10 ppm	0 - 10	20	0.2 ppm	<±0.5 ppm	0.01 ppm	<60 s	-20°C to 40°C	5 to 95%	10ppm
Sulphur dioxide 0 - 100 ppm	0 - 100	200	0.5 ppm	<±10%	0.1 ppm	<60 s	-20°C to 40°C	5 to 95%	100ppm
VOC 0 - 25ppm ³	0 - 25	50	0.1 ppm	<±10% 0.1-25 ppm	0.1 ppm	<60 s	-20°C to 40°C	5 to 95%	25ppm
VOC 0 - 500 ppm ⁴	0 - 500	1000	1 ppm	<±10%	1 ppm	<60 s	-20°C to 40°C	5 to 95%	500ppm
Other Gases	Contact Aeroqual with specific requirements for gas and concentration								

Appendix D Series 930 and 935 RS485 Communication Protocol

Protocol Version 1.5 Date: 01-02-2005

The network communication is in master-slave mode, which means that a PC or other device will be the network master. All information is requested by the network master. Otherwise no information is sent out by the S930/S935 network units.

Section 1. General description of the communication commands (for command details and data representations please refer section 4):

01. Information request command to S930/S935. The basic format is a 5 bytes data stream:

BASE, COMMAND, NETWORK_ID, OTHERS, CHECKSUM

- * BASE - information request data stream header
- * COMMAND - 1 byte network unit action command
- * NETWORK_ID - 1 byte S930/S935 network ID.
- * OTHERS - may used to extend functions later, it can be left as empty for now
- * CHECKSUM - makes the data stream total sum byte value to zero.

02. S930/S935 unit basic reply command format will be a 15 bytes stream (see Section 2 for details):

SENSOR, COMMAND, NETWORK_ID, DATA1(4 bytes), DATA2(4 bytes), RESERVED, STATUS1, STATUS2, CHECKSUM

Section 2. S930/S935 Network ID specified commands. These commands generate a response by a specified S930/S935 unit. Every command needs a corresponding reply.

01. Gas Data request command. The command asks for the gas data that a specific S930/S935 unit currently holds. The S930/S935 unit responds with an gas value. The gas data validity depends on the DATA_UNVALID bit of STATUS1 flag (please see Section 4 for details).

Command: BASE, GAS_CONC_DATA, NETWORK_ID, EMPTY, CHECKSUM

Reply: SENSOR, GAS_CONC_DATA, NETWORK_ID, DATA1, TEMP, RH, RESERVED, STATUS1, STATUS2, CHECKSUM

- * DATA1 - 4 bytes IEEE754 floating point data, measured gas value, if

DATA_UNVALID bit of STATUS1 flag is 1 then it will be last byte measured value, otherwise it's new measured value.

* TEMP - 2 bytes int value, its actual value equals the int value divided by 10 (TEMP/10) for its real temperature value of S935 unit

* RH - 2 bytes int value, its actual value equals the int value divided by 10 (RH/10) for its real relative humidity value of S935 unit

* for S930 the field TEMP and RH will be always zero for firmware version 1.5 and later.

* However, for S935 firmware version 1.4 and earlier can't use this command to request temperature and humidity.

02. Standby command. The S930/S935 unit will set its sensor head to standby state. The S930/S935 will set STANDBY bit of STATUS2 to 1 indicating it is in standby mode. When the standby state has been terminated, it will reset STANDBY bit of STATUS2 to 0.

Command: BASE, STANDBY, NETWORK_ID, EMPTY, CHECKSUM

Reply: SENSOR, STANDBY, NETWORK_ID, DATA1, DATA2, RESERVED, STATUS1, STATUS2, CHECKSUM

* DATA1 and DATA2 - no meanings.

The reply just confirms that it performed action, to find it check status bit.

03. Specific S930/S935 reset command. The command will reset the S930/S935 at any time.

Command: BASE, RESET, NETWORK_ID, EMPTY, CHECKSUM

Reply: SENSOR, RESET, NETWORK_ID, DATA1, DATA2, RESERVED, STATUS1, STATUS2, CHECKSUM

* DATA1 and DATA2 - no meanings.

* RESET - 1 byte reset command, see section 4 for details.

04. Specific S930/S935 unit connected sensor head version number request command and reply. PC or other devices can request sensor head version information through S930/S935 unit.

Command: BASE, SENSOR_VERSION, NETWORK_ID, EMPTY, CHECKSUM

Reply: SENSOR, SENSOR_VERSION, NETWORK_ID, VERSION_NUM, DISPLAY_TYPE, NAME_LENGTH, SENSOR_NAME, RESERVED, CHECKSUM

* VERSION_NUM - 1 byte, the version number of sensor head plugged in the S930/S935 unit. Real version number is the value divided by 10.

* DISPLAY_TYPE - 1 byte, the decimal value display type, different gas sensor head are different, see sensor head specifications for details

* NAME_LENGTH - 1 byte, the sensor head name length.

* SENSOR_NAME - 7 bytes max, valid length depends on NAME_LENGTH value, the sensor head name ASCII code that connected to S930/S935 unit,

05. Modify S930/S935 unit network ID command, that can change current S930/S935 unit network ID.

APPENDIX E- Calibrating the LED display

Aeroqual uses a DATEL DMS-30PC voltmeter display fitted with an adaptor board to enable it to measure 4-20 mA. The display is factory calibrated for the sensor head installed. If a different sensor needs to be installed or the fullscale needs to be changed then the display may need to be calibrated. This requires installing and/or selecting the correct shunt resistor, selecting the position of the decimal point and setting the zero trim pot.

The adaptor board is based on the DATEL recommended circuit shown below. R2 is the zero trim pot. R1 is the shunt resistor. Aeroqual usually installs 2 or 3 shunt resistors which can be switched in and out of the circuit in parallel using dipswitches to enable the correct resistor value to be achieved for the application. The value of R1 is calculated by:

$$R1 = V_{fullscale} / I_{fullscale}$$

For example:

For a 0-2 V display and a desired reading of 0.5 at 20 ma then the value of the R1 shunt resistor should be:

$$R1 = 0.5 / (0.020 - 0.004 \text{ A}) = 0.5 / 0.016 = 31.25 \text{ ohms}$$

Figure 1 DATEL recommended circuit for converting voltmeter to 4-20 mA current meter.

