

# **Model Q45H/64**

## **Dissolved Ozone Measurement System**

---

### **Home Office**

Analytical Technology, Inc.  
6 Iron Bridge Drive  
Collegeville, PA 19426  
Ph:(800) 959-0299  
(610) 917-0991  
Fax: (610) 917-0992  
Email: [sales@analyticaltechnology.com](mailto:sales@analyticaltechnology.com)

### **European Office**

Analytical Technology  
Bank Chambers, 33 Stamford St.  
Mossley, Ashton-u-Lyne OL50LL  
Ph: 0800-018-4020  
+ 44 (0) 1457 832800  
Fax: + 44 (0) 1457 839500  
Email: [sales@atiuk.com](mailto:sales@atiuk.com)

---

## PRODUCT WARRANTY

Analytical Technology, Inc. (Manufacturer) warrants to the Customer that if any part(s) of the Manufacturer's products proves to be defective in materials or workmanship within the earlier of 18 months of the date of shipment or 12 months of the date of start-up, such defective parts will be repaired or replaced free of charge. Inspection and repairs to products thought to be defective within the warranty period will be completed at the Manufacturer's facilities in Collegeville, PA. Products on which warranty repairs are required shall be shipped freight prepaid to the Manufacturer. The product(s) will be returned freight prepaid and allowed if it is determined by the manufacturer that the part(s) failed due to defective materials or workmanship.

This warranty does not cover consumable items, batteries, or wear items subject to periodic replacement including lamps and fuses.

Gas sensors, except oxygen sensors, are covered by this warranty, but are subject to inspection for evidence of extended exposure to excessive gas concentrations. Should inspection indicate that sensors have been expended rather than failed prematurely, the warranty shall not apply.

The Manufacturer assumes no liability for consequential damages of any kind, and the buyer by acceptance of this equipment will assume all liability for the consequences of its use or misuse by the Customer, his employees, or others. A defect within the meaning of this warranty is any part of any piece of a Manufacturer's product which shall, when such part is capable of being renewed, repaired, or replaced, operate to condemn such piece of equipment.

This warranty is in lieu of all other warranties (including without limiting the generality of the foregoing warranties of merchantability and fitness for a particular purpose), guarantees, obligations or liabilities expressed or implied by the Manufacturer or its representatives and by statute or rule of law.

This warranty is void if the Manufacturer's product(s) has been subject to misuse or abuse, or has not been operated or stored in accordance with instructions, or if the serial number has been removed.

Analytical Technology, Inc. makes no other warranty expressed or implied except as stated above.

# Table of Contents

<b>PART 1 - INTRODUCTION .....</b>	<b>4</b>
1.1 General.....	4
1.2 Standard System .....	5
Figure 1-1 Typical Ozone Monitoring System (ATI-0648).....	5
1.3 Features .....	6
1.4 Q45H/64 System Specifications .....	8
1.5 Q45H Performance Specifications.....	10
<b>PART 2 – ANALYZER MOUNTING .....</b>	<b>11</b>
2.1 General.....	11
Figure 2-1 Q45 Enclosure Dimensions, AC Powered Units (ATI-0706) .....	12
Figure 2-2 Q45 Enclosure Dimensions, 2-Wire and Battery Units (ATI-0655).....	13
2.2 Wall or Pipe Mount.....	14
Figure 2-3 Wall or Pipe mount Bracket (ATI-0707).....	14
Figure 2-4 Wall Mounting Diagram (ATI-0709).....	15
Figure 2-5 Pipe Mounting Diagram (ATI-0710).....	15
2.3 Panel Mount, AC Powered Monitor.....	16
Figure 2-6 115/230 VAC Panel Mount and Cut-out (ATI-0711).....	16
<b>PART 3 – SENSOR/FLOWCELL MOUNTING .....</b>	<b>17</b>
3.1 General.....	17
3.2 Constant-Head Flowcell .....	17
Figure 3-1 Constant Head Flowcell Details (ATI-0196).....	17
3.3 Low-Volume Flowcell .....	18
Figure 3-2 Low Volume Flowcell Details (ATI-0264) .....	18
3.4 Submersion Mounting.....	19
Figure 3-3 Submersible Sensor Mounting Assembly (ATI-0155).....	20
<b>PART 4 – ELECTRICAL INSTALLATION.....</b>	<b>21</b>
4.1 General.....	21
4.2 Two-Wire.....	21
Figure 4-1 Loop-Power Connection, Q45H Transmitter (ATI-0658) .....	22
4.2.1 Load Drive.....	23
4.3 115/230 VAC w/Relays.....	23
Figure 4-2 Line Power Connection (ATI-0713) .....	25
Figure 4-3 Relay Contacts (ATI-0712) .....	26
4.4 Sensor Wiring.....	26
4.5 Direct Sensor Connection.....	26
Figure 4-4 Sensor Cable Preparation.....	27
4.6 Junction Box Connection .....	28
Figure 4-5 Junction Box Interconnect Wiring (ATI-0714).....	28
4.7 Optional pH Sensor Input.....	29
Figure 4-6 Optional pH Sensor Connection (ATI-0660).....	30
Figure 4-7 Optional pH Sensor Connection w/Junction Box (ATI-0716).....	31
<b>PART 5 – SENSOR ASSEMBLY .....</b>	<b>32</b>
5.1 Ozone Sensor Preparation .....	32
Figure 5-1 Ozone Sensor Assembly (ATI-0294).....	32
5.2 Optional pH Sensor.....	34
<b>PART 6 – CONFIGURATION.....</b>	<b>35</b>
6.1 User Interface .....	35

Figure 6-1 User Interface (ATI-0654).....	35
6.11 Keys .....	36
6.12 Display .....	36
6.2 Software .....	38
6.21 Software Navigation.....	38
Figure 6-2 Software Map .....	40
6.22 Measure Menu [MEASURE].....	41
6.23 Calibration Menu [CAL] .....	42
6.24 Configuration Menu [CONFIG].....	43
6.25 Control Menu [CONTROL].....	47
Figure 6-3 Control Relay Example, Hysteresis and Two Opposite Phase Options .....	51
Figure 6-4 Alarm Relay Example .....	52
6.26 Diagnostics Menu [DIAG] .....	53
<b>PART 7 – CALIBRATION.....</b>	<b>57</b>
7.1 Ozone Calibration .....	57
7.11 Ozone Zero Cal .....	57
7.12 Ozone Span Cal.....	58
7.2 Temperature Calibration.....	60
7.3 pH Calibration .....	61
7.31 Two-Point pH Cal .....	61
7.32 One-Point pH Cal.....	62
<b>PART 8 – PID CONTROLLER DETAILS .....</b>	<b>64</b>
8.1 PID Description .....	64
8.2 PID Algorithm .....	64
Figure 8-1 Q45H ISA (Ideal) PID Equation .....	65
8.3 Classical PID Tuning .....	66
8.4 Common PID Pitfalls .....	67
<b>PART 9 – SYSTEM MAINTENANCE.....</b>	<b>68</b>
9.1 General.....	68
9.2 Analyzer Maintenance.....	68
9.3 Ozone Sensor Maintenance .....	68
9.31 Sensor Acid Cleaning.....	69
9.4 Flow Cell Maintenance .....	70
<b>PART 10 – TROUBLESHOOTING .....</b>	<b>71</b>
10.1 General.....	71
10.2 External Sources of Problems.....	71
10.3 Analyzer Tests .....	72
10.4 Display Messages .....	74
Figure 10-1 Q45H Display Messages .....	74
Figure 10-1 Q45H Display Messages (continued).....	75
10.5 Sensor Tests.....	76
Figure 10-2 Pt100 RTD Table .....	77
<b>SPARE PARTS .....</b>	<b>78</b>

# Part 1 - Introduction

---

## 1.1 General

The Model Q45H/64 is a highly versatile on-line monitoring system designed for the continuous measurement of dissolved ozone in solution. The full scale operating range of the system may be selected by the user for 0-200.0 ppb, 0-2.000 ppm, 0-20.00 ppm, or 0-200.0 ppm, and the sensing system will operate on water streams with temperatures ranging from 0 to 55°C. The Q45H/64 Dissolved Ozone Measurement System is well suited for potable water systems, bottled water operations, high purity water systems, or ozonated cooling water.

The basic sensing element used in the dissolved ozone monitor is a polarographic membrane sensor which measures ozone directly. Water simply flows past the sensor and directly to drain, with the flow rate and pressure across the sensor controlled by a constant head flow cell assembly. The ozone measurement does not alter the sample or add any chemicals to the sample stream, so the water flow can return to the system if desired.

Q45H/64 Monitors are available in three electronic versions, a loop-powered 2-wire transmitter, an AC powered monitor with integral alarm relays and dual 4-20 mA output capability, or a 9 VDC battery operated portable unit with two voltage outputs and built-in data logger.

In addition to normal ozone measurement, the Q45H/64 is also available with an optional pH input which provides a two-parameter monitoring system. On AC or battery operated units, analog outputs are available for BOTH ozone and pH.

### 1.2 Standard System

The standard model Q45H/64 system includes three main components, the Q45H analyzer, a constant head flow cell, and an ozone sensor. A low-volume flowcell is also available for applications where sample flowrate and pressure can be carefully controlled. Figure 1-1 shows a typical installation including the optional pH sensor.

For connection of the sensor to the electronics, a 25' cable is supplied. An additional 100 feet of interconnect cable may be added using #07-0100 junction box. All required spare parts are also provided with the basic system, including spare membranes, electrolyte, o-rings, and any special hardware.

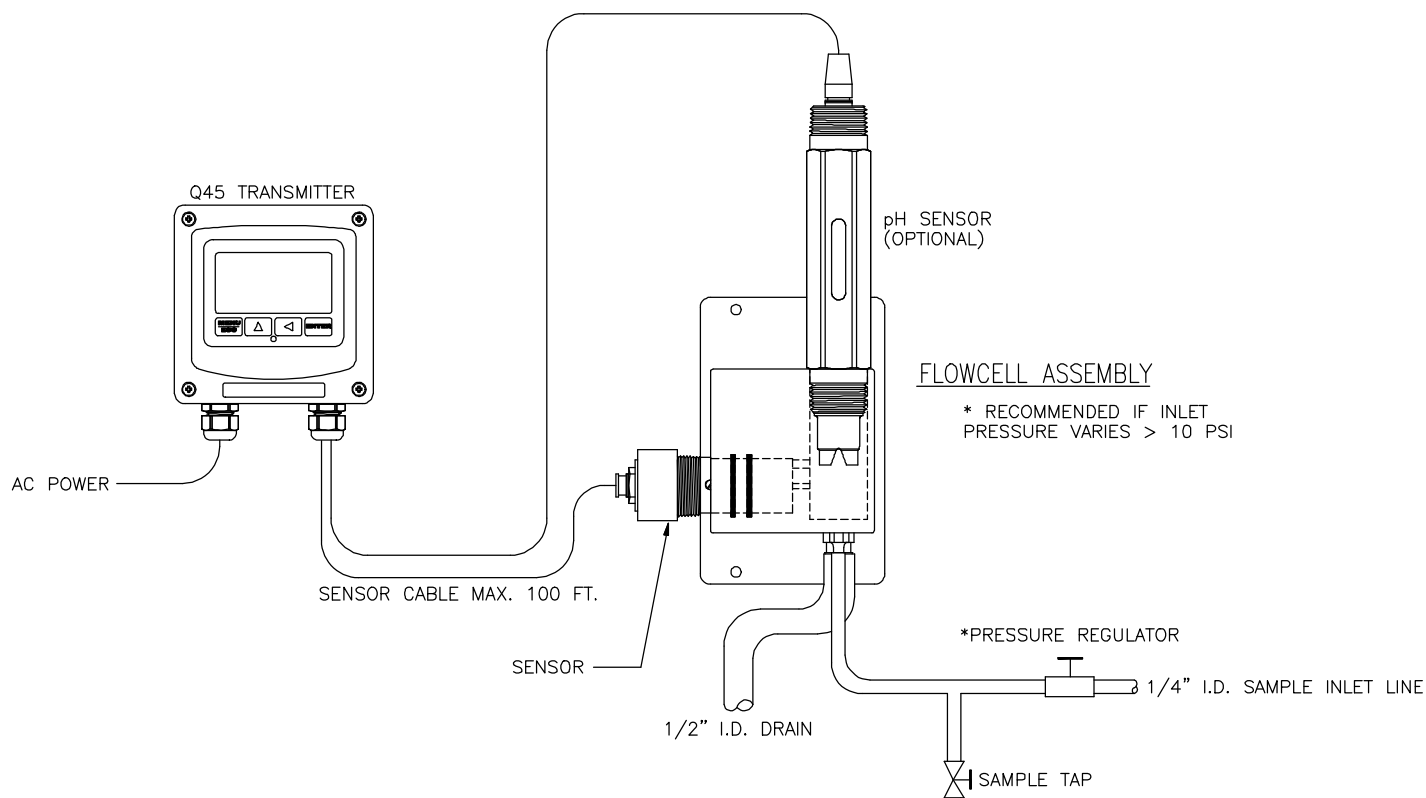

**Figure 1-1 Typical Ozone Monitoring System (ATI-0648)**

### 1.3 Features

- Standard Q45H/64 electronic transmitters are designed to be a fully isolated, loop powered instruments for 2-wire DC applications. Optional integral power supply card for 115/230 VAC operation, and optional battery power supply card for portable datalogging applications are available.
- High accuracy, high sensitivity system, measures from 0.1 ppb to 200.0 ppm through 4 internal automatic ranges. User ranges of 200.0 ppb, 2.000 ppm, 20.00 ppm, or 200.0 ppm.
- Output Hold, Output Simulate, Output Alarm, and Output Delay Functions. All forced changes in output condition include bumpless transfer to provide gradual return to on-line signal levels and to avoid system control shocks on both analog outputs.
- AC power option provides dual SPDT relay operation and one additional isolated analog output. Software settings for relay control include setpoint, deadband, phase, delay, and failsafe. Software controls automatically appear in menu list when hardware option card is plugged in and system power is applied.
- Selectable PID controller on main analog output. PID controller can operate with instrument configured as loop-power transmitter, or as one of the two outputs on the AC powered instrument. PID includes manual operation feature, and diagnostic “stuck-controller” timer feature for relay notification of control problems.
- Two analog outputs on the relay version may be configured to track ozone and temperature, ozone and ozone, or ozone and pH. Both analog outputs can be individually programmed to fail to specific values.
- Optional pH sensor feature enables active pH measurement with the Q45H/64 monitor. The pH reading can also be sent to one of the analog outputs for complete pH + ozone monitoring.
- Selectable Output Fail Alarm feature on Relay B allows system diagnostic failures to be sent to external monitoring systems.
- Large, high contrast, custom Super-Twist display provides excellent readability even in low light conditions. The secondary line of display utilizes 5x7 dot matrix characters for clear message display Two of four measured parameters may be on the display simultaneously.
- Diagnostic messages provide a clear description of any problem with no confusing error codes to look up. Messages are also included for diagnosing

calibration problems.

- Quick and easy one-point calibration method and sensor zero-cal. To provide high accuracy, all calibration methods include stability monitors that check temperature and main parameter stability before accepting data.
- High accuracy three-wire Pt100 temperature input. Temperature element can be user calibrated.
- Security lock feature to prevent unauthorized tampering with transmitter settings. All settings can be viewed while locked, but they cannot be changed.
- High reliability, microprocessor-based system with non-volatile memory back-up that utilizes no batteries. Low mass, surface mount PCB construction containing no adjustment potentiometers. All factory calibrations stored in non-volatile EEPROM.

## 1.4 Q45H/64 System Specifications

### (Common to all variations)

<b>Displayed Parameters</b>	Main input, 0.1 ppb (0.0001 ppm) to 200.0 ppm Sensor temperature, -10.0 to 55.0 °C (23 to 131 °F) Sensor Current, 0.0–999.9 nA, 0.000 to 99.99 uA Loop current, 4.00 to 20.00 mA Sensor slope/offset Model number and software version PID Controller Status Optional pH Input value. 0.00 to 14.00 pH
<b>Main Parameter Ranges</b>	Manual selection of one of the following ranges, 0.000 to 200.0 ppb 0.0 to 2.000 ppm 0.00 to 20.00 ppm 0.00 to 200.0 ppm
<b>Display</b>	Large, high-contrast, Super-Twist (STN) LCD; 4-digit main display with sign, 0.75" (19.1 mm) seven-segment characters 12-digit secondary display, 0.3" (7.6 mm) 5x7 dot matrix characters
<b>Keypad</b>	4-key membrane type with tactile feedback, polycarbonate with UV coating
<b>Weight</b>	DC transmitter configuration: 1 lb. (0.45 kg) Line powered unit: 1.5 lb. (0.68 kg)
<b>Ambient Temperature</b>	Analyzer Service, -20 to 60 °C (-4 to 140 °F) Sensor Service, -5 to 55°C (23 to 131 °F) Storage, -5 to 70 °C (-22 to 158 °F)
<b>Ambient Humidity</b>	0 to 95%, indoor/outdoor use, non-condensing to rated ambient temperature range
<b>Altitude</b>	Up to 2000 m (6562 Ft.)
<b>Electrical Certification</b>	Ordinary Location, cCSAus (CSA and UL standards - both approved by CSA), pollution degree 2, installation category 2
<b>EMI/RFI Influence</b>	Designed to EN 61326-1
<b>Output Isolation</b>	600 V galvanic isolation
<b>Filter</b>	Adjustable 0-9.9 minutes additional damping to 90% step input

<b>Temperature Input</b>	Pt100 RTD with automatic compensation
<b>Sensor</b>	2-electrode polarographic membraned sensor for direct measurement of ozone,
<b>Sensor Materials</b>	Noryl and stainless steel
<b>Sensor Cable</b>	25 ft. (7.5 meter) cable with 6-pin plug.
<b>Max. Sensor-to-Analyzer Distance</b>	100 feet (30.5 meters), with junction box
<b>Optional pH Input</b>	0-14 pH corresponding to approx. 0.3 – 1.5 VDC
<b>Flow Cell</b>	Constant head overflow, clear cast acrylic, 7-30 GPH, 15 GPH recommended, inlet is ¼" hose barb at 1/8" MNPT, outlet is ½" hose barb at 3/8" MNPT

**(NOT common to all variations)**

**Standard 2-Wire (Loop-powered) Transmitter:**

<b>Power</b>	16-35 VDC (2-wire device)
<b>Enclosure:</b>	NEMA 4X, polycarbonate, stainless steel hardware, weatherproof and corrosion resistant, HWD: 4.4" (112 mm) x 4.4" (112 mm) x 3.5" (89 mm)
<b>Mounting Options</b>	Wall or pipe mount bracket standard. Bracket suitable for either 1.5" or 2" I.D. U-Bolts for pipe mounting.
<b>Conduit Openings</b>	Two PG-9 openings with gland seals
<b>DC Cable Type</b>	Belden twisted-pair, shielded, 22 gauge or larger
<b>Insertion Loss</b>	16 VDC

**115/230 VAC + Dual Relay Option:**

<b>Power</b>	115/230 VAC ± 10%, 50/60 Hz, 10 VA max
<b>Enclosure, AC Powered</b>	NEMA 4X, polycarbonate, stainless steel hardware, weatherproof and corrosion resistant, HWD: 4.9" (124 mm) x 4.9" (124 mm) x 5.5" (139 mm)
<b>Mounting Options</b>	Wall or pipe mount bracket standard. Bracket suitable for either 1.5" or 2" I.D. U-Bolts for pipe mounting. Panel mount adapter optional.
<b>Conduit Openings</b>	Three ½" NPT openings. Gland seals supplied but not installed.

**Relays, Electromechanical:** Two SPDT, 6 amp @ 250 VAC, 5 amp @ 24 VDC contacts. Software selection for setpoint, phase, delay, deadband, hi-lo alarm, and failsafe. A-B indicators on main LCD.

**Analog Outputs** Two 4-20 mA outputs. Output one programmable for PPM ozone or PID. Output 2 programmable for PPM ozone, Temperature, or pH. Max load 500 Ohms for each output. Outputs ground isolated and isolated from each other.

**1.5 Q45H Performance Specifications**

**(Common to all variations)**

<b>Accuracy</b>	0.5% of selected range or 0.02 PPM
<b>Repeatability</b>	0.3% of selected range or 0.01 PPM
<b>Sensitivity</b>	0.05% of selected range
<b>Non-linearity</b>	0.1% of selected range
<b>Warm-up Time</b>	3 seconds to rated performance (electronics only)
<b>Supply Voltage Effects</b>	± 0.05% span
<b>Instrument Response Time</b>	60 seconds to 90% of step input at lowest damping

## Part 2 – Analyzer Mounting

---

### 2.1 General

All Q45 Series instruments offer maximum mounting flexibility. A bracket is included with each unit that allows mounting to walls or pipes. In all cases, choose a location that is readily accessible for calibrations. Also consider that it may be necessary to utilize a location where solutions can be used during the calibration process. To take full advantage of the high contrast display, mount the instrument in a location where the display can be viewed from various angles and long distances.

Locate the instrument in close proximity to the point of sensor installation - this will allow easy access during calibration. The sensor-to-instrument distance should not exceed 100 feet. To maximize signal-to-noise ratio however, work with the shortest sensor cable possible. The standard cable length of the ozone sensor is 25 feet.

Due to the flexibility of the instrument design, some of the mounting features change based on the configuration that was ordered. For example, the 2-wire transmitter version is different for the 115/230 VAC controller because the rear of the enclosure is much deeper when the AC powered unit is used. In addition, the AC powered unit has an integrated panel mount flange requiring a single cutout for flush mounting. In the 2-wire transmitter configuration, just the front of the enclosure can be mounted, but the cutout also requires accurate location of 4 mounting holes. Refer to Figures 2-1 and 2-2 for detailed dimensions of each type of system.

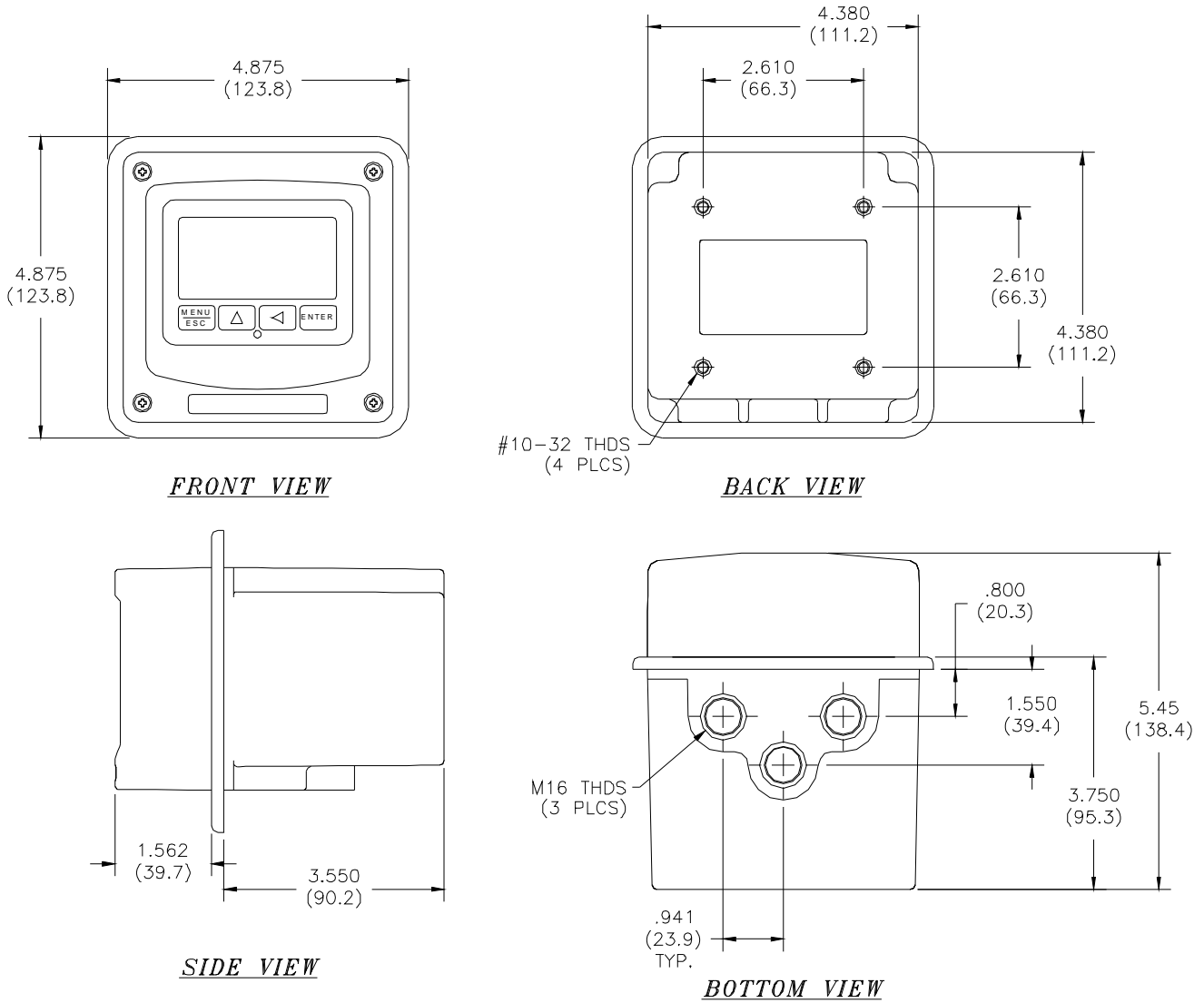

**Figure 2-1 Q45 Enclosure Dimensions, AC Powered Units (ATI-0706)**

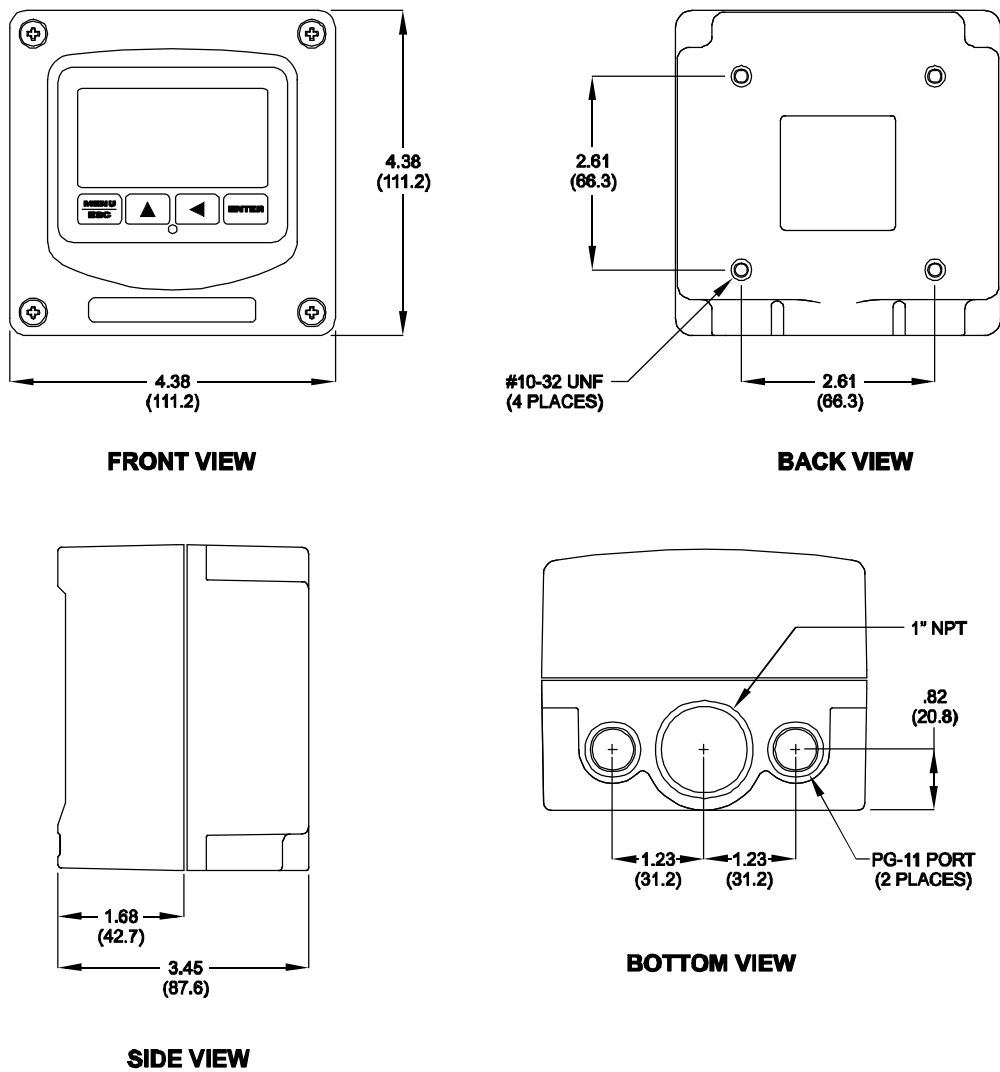

**Figure 2-2 Q45 Enclosure Dimensions, 2-Wire and Battery Units (ATI-0655)**

## 2.2 Wall or Pipe Mount

A PVC mounting bracket with attachment screws is supplied with each transmitter (see Figure 2-3 for dimensions). The multi-purpose bracket is attached to the rear of the enclosure using the four flat head screws. The instrument is then attached to the wall using the four outer mounting holes in the bracket. These holes are slotted to accommodate two sizes of u-bolt that may be used to pipe mount the unit. Slots will accommodate u-bolts designed for 1½ “ or 2” pipe. The actual center to center dimensions for the u-bolts are shown in the drawing. Note that these slots are for u-bolts with ¼-20 threads. The 1½” pipe u-bolt (2” I.D. clearance) is available from ATI in type 304 stainless steel under part number (47-0005).

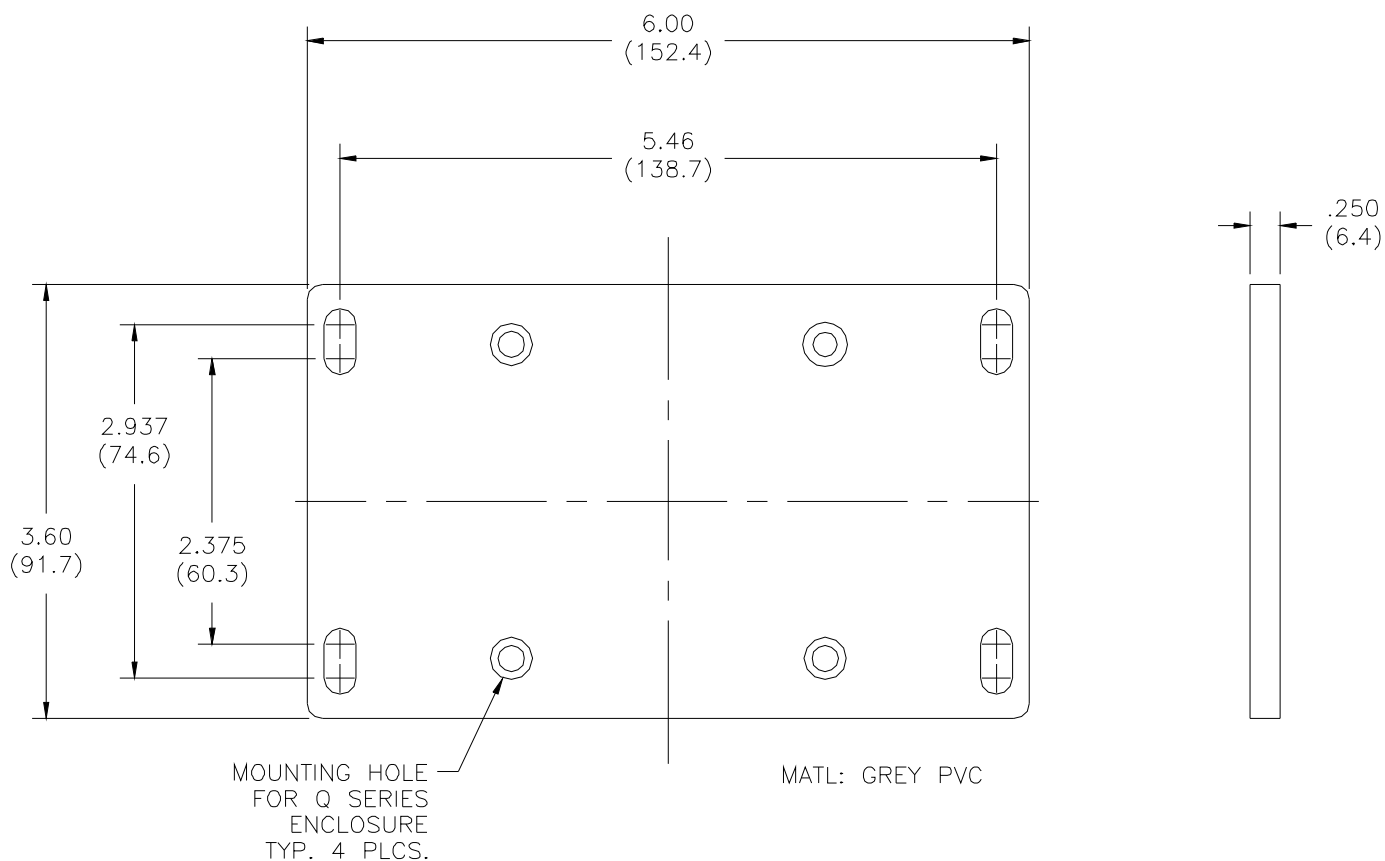

**Figure 2-3 Wall or Pipe mount Bracket (ATI-0707)**

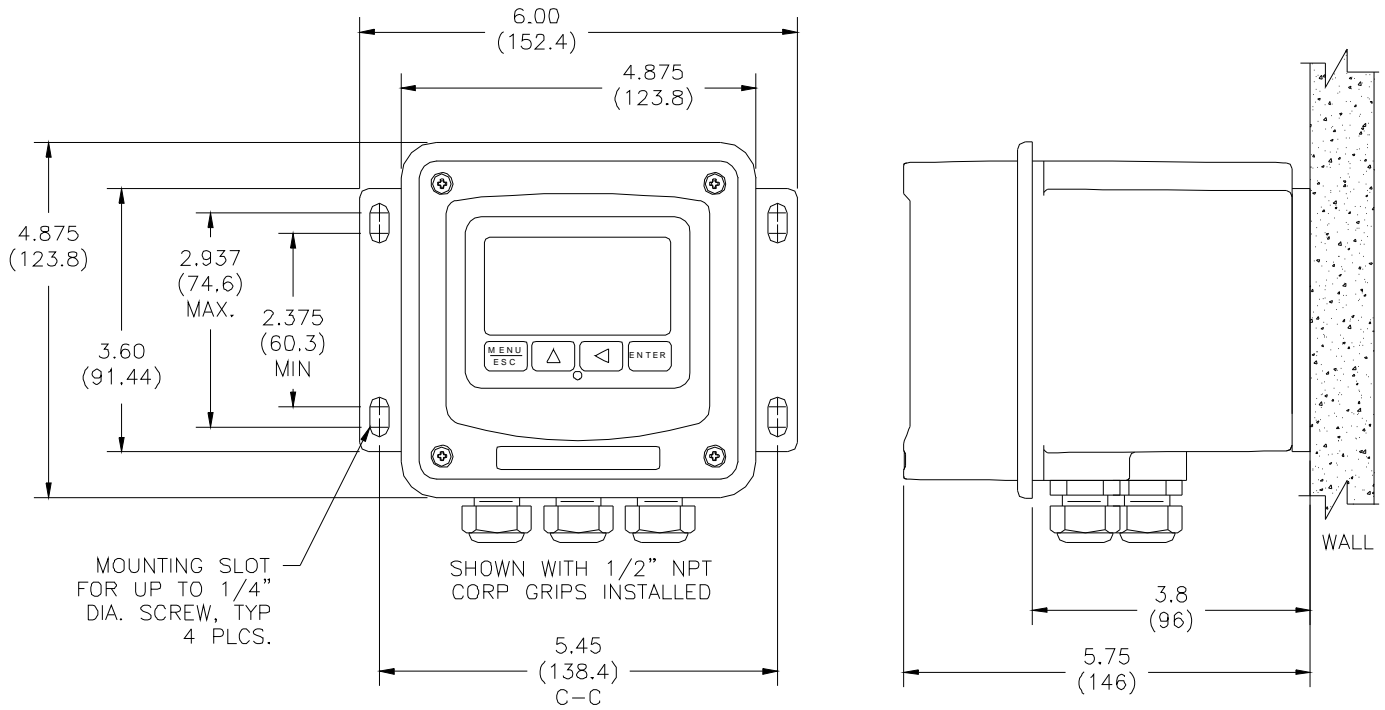

**Figure 2-4 Wall Mounting Diagram (ATI-0709)**

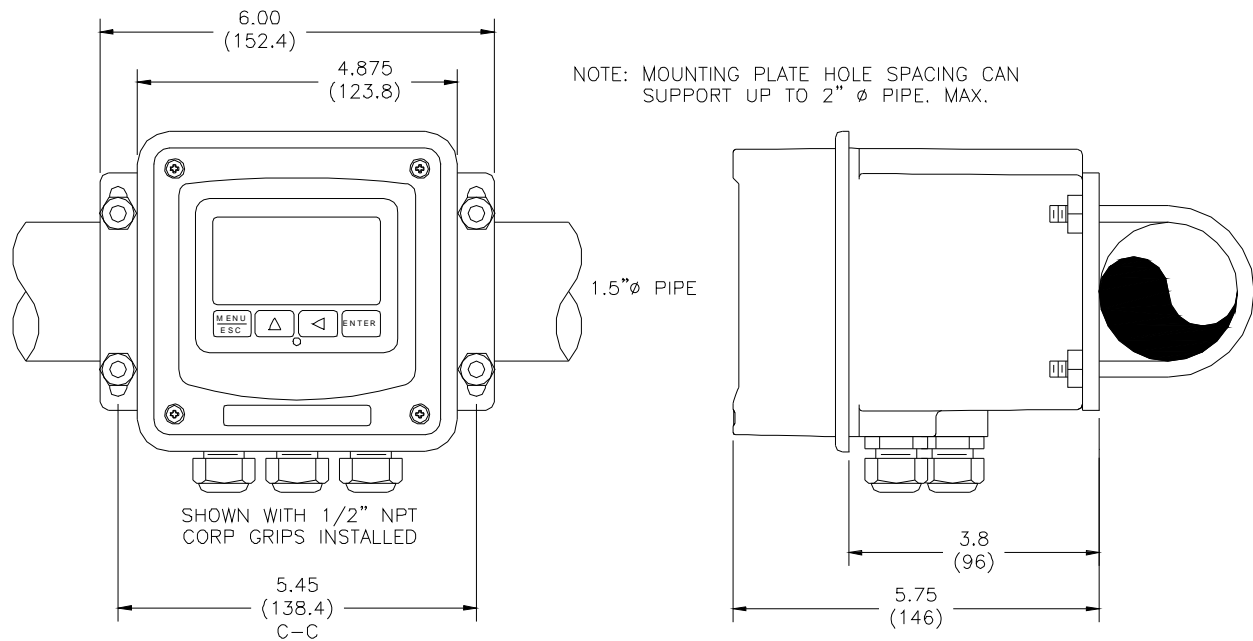

**Figure 2-5 Pipe Mounting Diagram (ATI-0710)**

### 2.3 Panel Mount, AC Powered Monitor

Panel mounting of an AC powered monitor uses the panel mounting flange molded into the rear section of the enclosure. Figure 2-7 provides dimensions for the panel cutout required for mounting.

The panel mounting bracket kit must be ordered separately (part number 05-0068). This kit contains a metal retainer bracket that attaches to the rear of the enclosure, 4 screws for attachment of this bracket, and a sealing gasket to insure that the panel mounted monitor provides a water tight seal when mounted to a panel.

The sealing gasket must first be attached to the enclosure. The gasket contains an adhesive on one side so that it remains in place on the enclosure. Remove the protective paper from the adhesive side of the gasket and slide the gasket over the back of the enclosure so that the adhesive side lines up with the back of the enclosure flange. Once in place, you can proceed to mount the monitor in the panel.

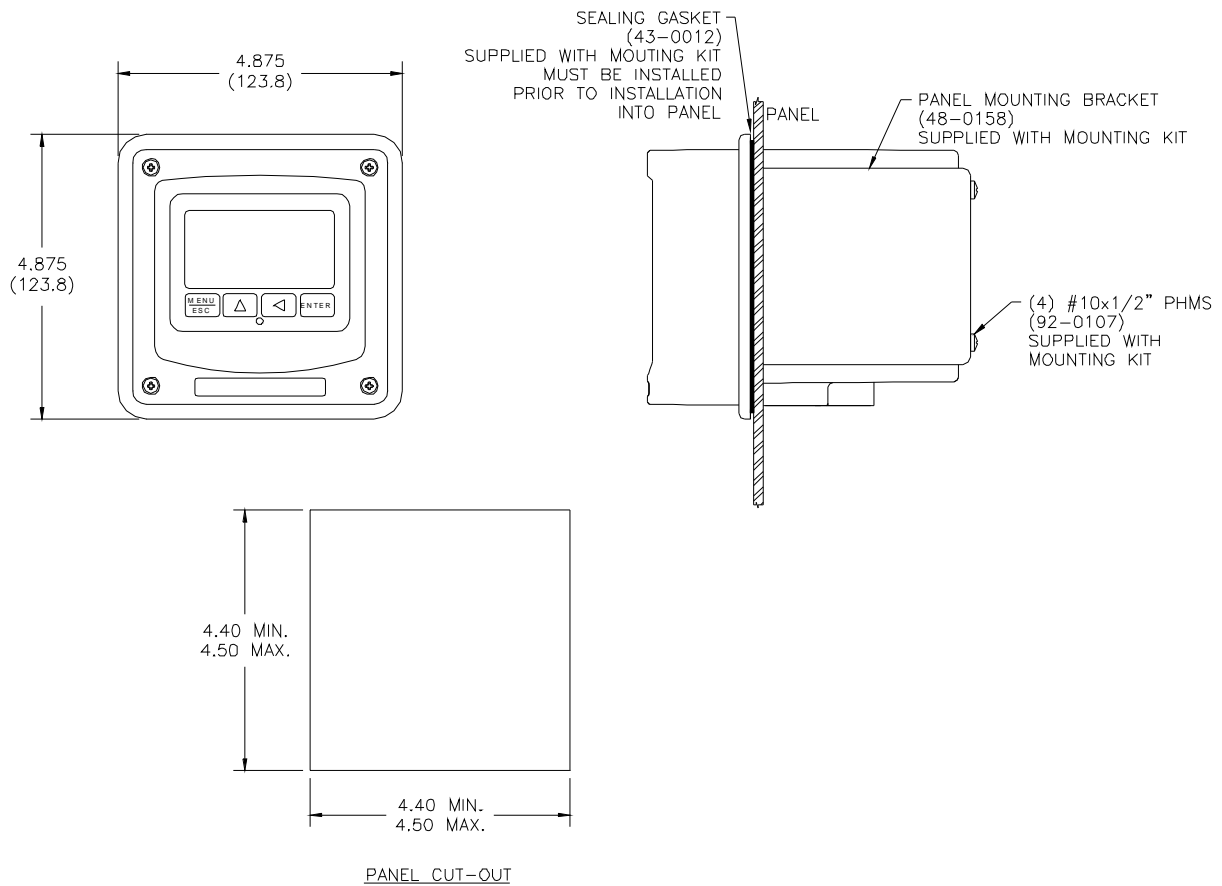

**Figure 2-6 115/230 VAC Panel Mount and Cut-out (ATI-0711)**

## Part 3 – Sensor/Flowcell Mounting

### 3.1 General

Select a location within the maximum sensor cable length for mounting of the sensor flow cell.

### 3.2 Constant-Head Flowcell

Ozone sensors are best used in a constant-head overflow chamber because variations in sample flow rate and pressure can cause unstable readings. When monitoring low concentrations (below 0.5 PPM), this method should always be used.

Mechanical installation of the flow cell requires that it be mounted to a wall or other convenient flat surface. Alternatively, the mounting holes on the plate will accommodate a 2" U-bolt for mounting the plate to a 2" pipe. Figure 3-1 shows the dimensions and mounting hole locations for the flow cell. Be sure to allow enough clearance on the left side of the flow cell for insertion and removal of the sensor. About 12 inches clearance is recommended.

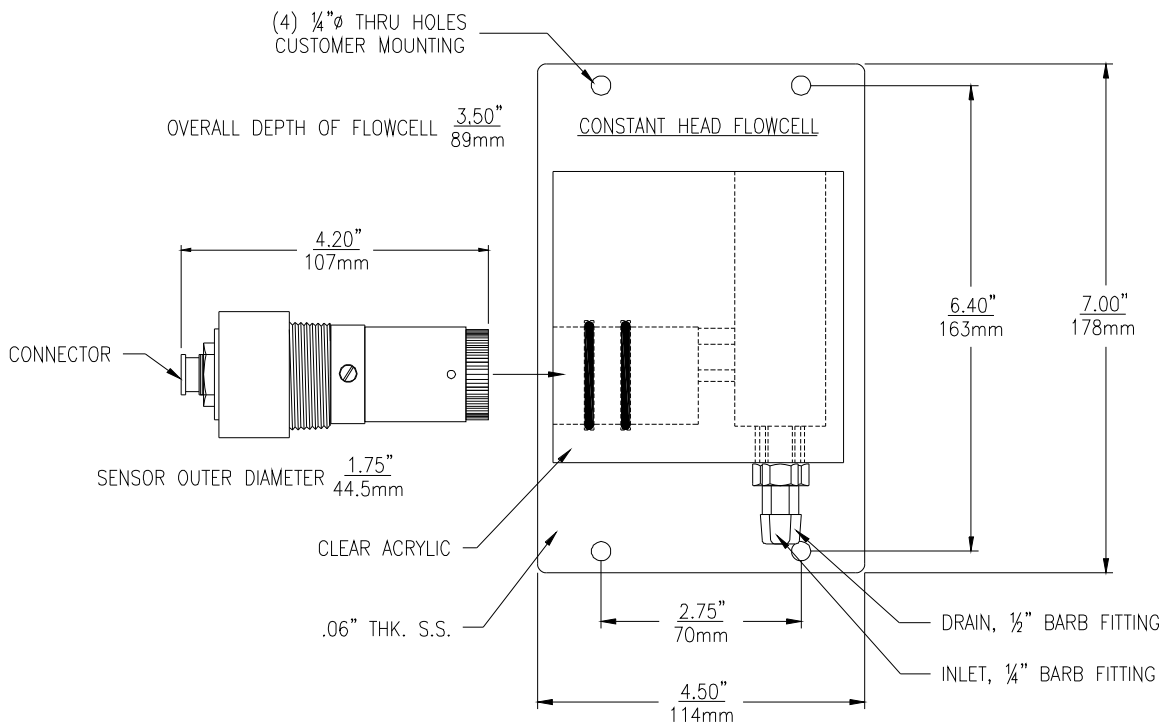
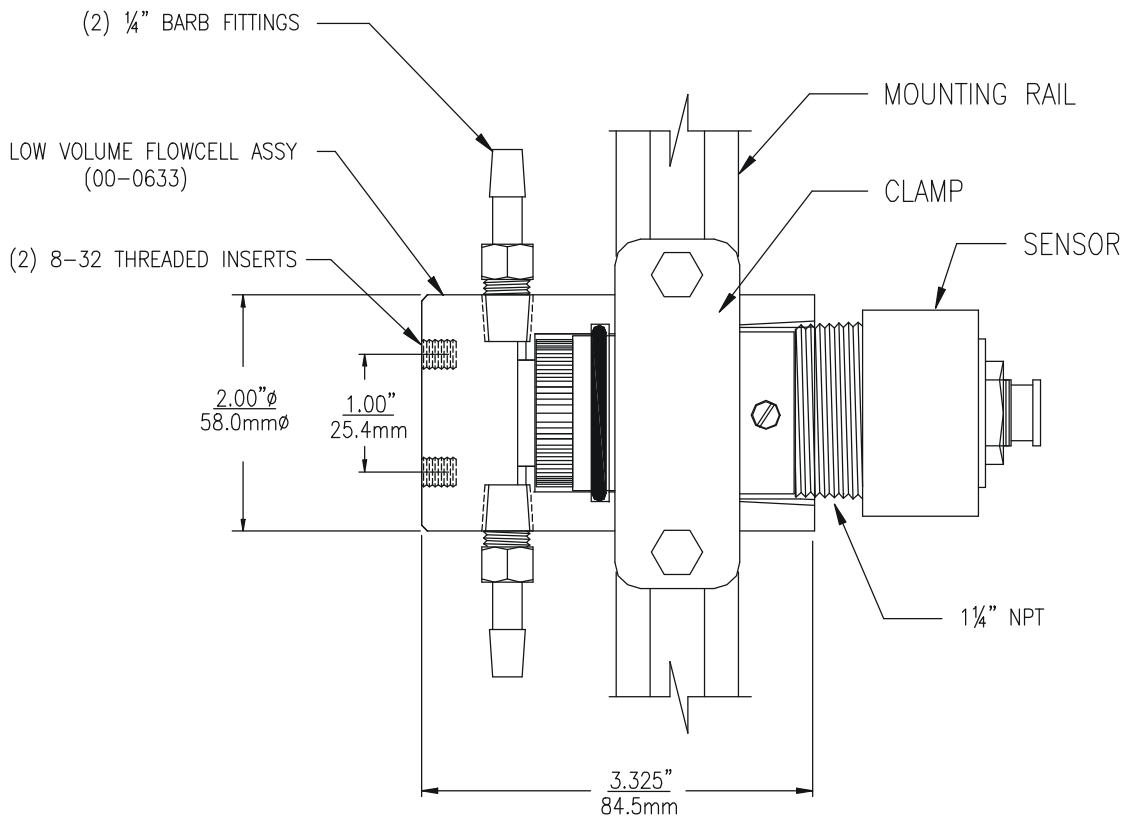

**Figure 3-1 Constant Head Flowcell Details (ATI-0196)**

Once mounted, inlet and drain connections must be made. The flow cell contains a 1/8" MNPT inlet connection and a 3/8" MNPT drain connection. Hose bars for the inlet and drain connections are supplied with the flow cell for use with flexible tubing. The inlet hose barb is used with 1/4" I.D. tubing and the drain hose barb is used with 1/2" I.D. tubing.

### 3.3 Low-Volume Flowcell

Dissolved ozone sensors can sometimes be used in special low-volume flow cells to reduce the amount of water consumed by the monitor. This flow cell contains hose bars for 1/4" I.D. tubing on the inlet and outlet. The female thread in the flow cell is 1/8" NPT, and other fitting may be used in place of the hose bars if desired. See Figure 3-2.



**Figure 3-2 Low Volume Flowcell Details (ATI-0264)**

Great care must be taken in using the low-volume flow cell. Passages are very small, so only very clean water may be put through this type of system. The suggested flow rate is 200-400 cc/min., but the flow rate must be maintained precisely. The flow rate should not be allowed to vary by more than  $\pm 5$  cc/min. A rotameter installed on the inlet side of the flow cell should be used to set and maintain the flow. The drain line should contain a vacuum break if the outlet tubing is more than 3 feet (1 meter) in length.

To avoid air bubbles trapping under the membrane in the flow cell, the flow cell should be mounted in the horizontal plane with the inlet at the bottom and the outlet at the top. With flow always moving upward, air will be swept out of the cell and will not accumulate. Figure 3-2 shows mounting of the low volume flow cell using the optional clamp assembly.

### 3.4 Submersion Mounting

Some applications are much easier done using the submersible sensor. This method can sometimes be used where flow is reasonably constant, and hydraulic head does not vary appreciably. Ozone sensors can never be used in completely stagnant conditions. A flow velocity of at least 0.3 feet per second is normally required for measurement. Any applications for a submersible ozone sensor should first be discussed with ATI. A trial of such installations may be necessary.

Submersible sensors are mounted to a 1" pipe using a standard 1" PVC thread by thread pipe coupling. The mounting pipe can be secured to standard 1½" pipe rail using a mounting bracket kit available from ATI (part number 00-0628) as shown in Figure 3-3.

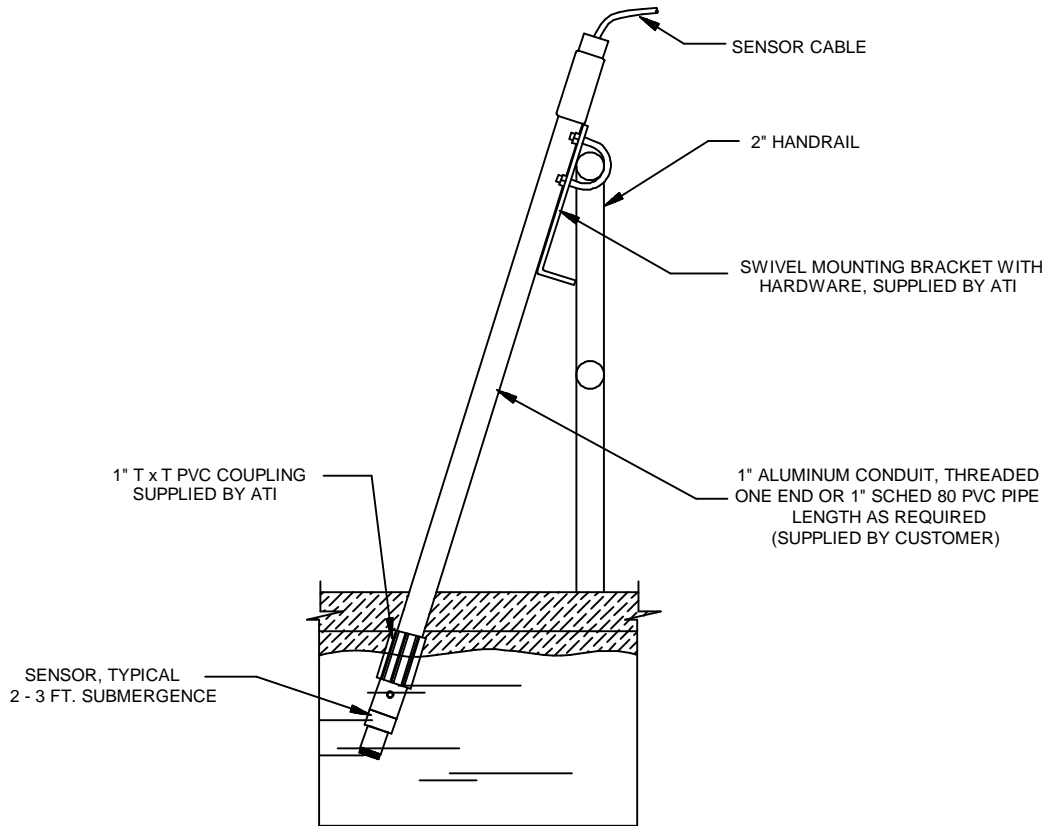

**Figure 3-3 Submersible Sensor Mounting Assembly (ATI-0155)**

## Part 4 – Electrical Installation

---

### 4.1 General

The Q45 is powered in one of two ways, depending on the version purchased. The 2-wire version is a 16-35 VDC powered transmitter. The integral 115/230 VAC version requires line power. Please verify the type of unit before connecting any power.

**WARNING: Do not connect AC line power to the 2-wire module. Severe damage will result.**

#### Important Notes:

1. Use wiring practices that conform to all national, state and local electrical codes. For proper safety as well as stable measuring performance, it is important that the earth ground connection be made to a solid ground point from terminal 15 (Figure 4-1). The AC power supply contains a single 100mA (115V) or 50mA (230V) slo-blo fuse. The fuse **F1** is located adjacent to **TB5** and is easily replaceable.
2. Do NOT run sensor cables or instrument 4-20 mA output wiring in the same conduit that contains AC power wiring. AC power wiring should be run in a dedicated conduit to prevent electrical noise from coupling with the instrumentation signals.
3. This analyzer must be installed by specifically trained personnel in accordance with relevant local codes and instructions contained in this operating manual. Observe the analyzer's technical specifications and input ratings. Proper electrical disconnection means must be provided prior to the electrical power connected to this instrument, such as a circuit breaker - rated 250 VAC, 2 A minimum. If one line of the line power mains is not neutral, use a double-pole mains switch to disconnect the analyzer.

### 4.2 Two-Wire

In the two-wire configuration, a separate DC power supply must be used to power the instrument. The exact connection of this power supply is dependent on the control system into which the instrument will connect. See Figure 4-1 for further details. Any twisted pair shielded cable can be used for connection of the instrument to the power supply. Route signal cable away from AC power lines, adjustable frequency drives, motors, or other noisy electrical signal lines. Do not run sensor or signal cables in conduit that contains AC power lines or motor leads.

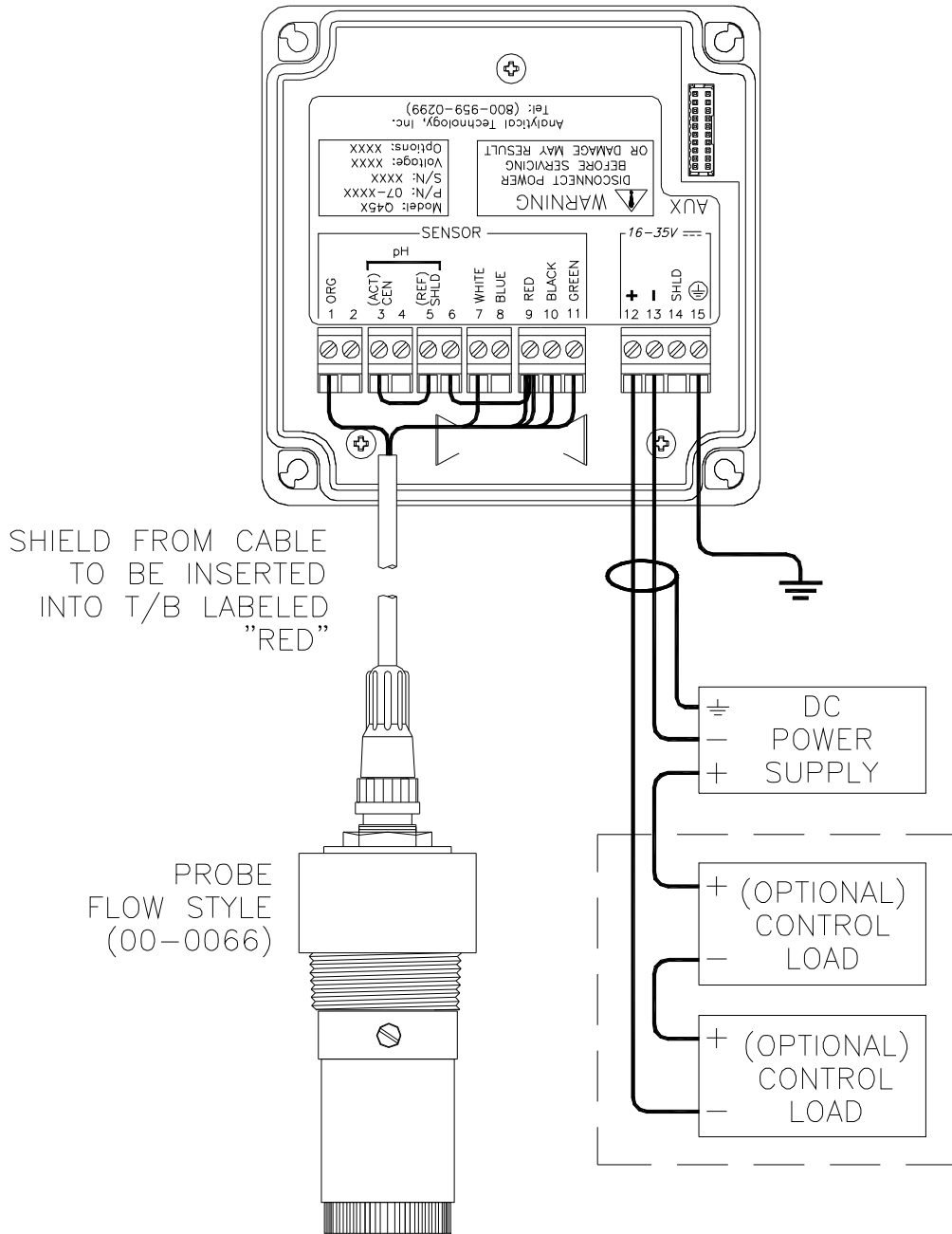

**Figure 4-1 Loop-Power Connection, Q45H Transmitter (ATI-0658)**

- Notes:**
1. Voltage between Terminals 12 and 13 MUST be between 16 and 35 VDC.
  2. Earth ground into Terminal 15 is HIGHLY recommended. This connection can greatly improve stability in electrically noisy environments.

#### 4.21 Load Drive

The amount of resistance that the analog output can drive in the 115/230 VAC version is fixed. However, in the two-wire configuration, the load-drive level is dependant on the DC supply voltage provided to the controller.

The two-wire instrument can operate on a power supply voltage of between 16 and 35 VDC. The available load drive capability can be calculated by applying the formula  $V/I=R$ , where  $V$ =load drive voltage,  $I$ =maximum loop current (in Amperes), and  $R$ =maximum resistance load (in Ohms).

To find the load drive voltage of the two-wire Q45, subtract 16 VDC from the actual power supply voltage being used (the 16 VDC represents insertion loss). For example, if a 24 VDC power supply is being used, the load drive voltage is 8 VDC.

The maximum loop current of the two-wire Q45 is always 20.00 mA, or .02 A. Therefore,

$$\frac{(\text{Power Supply Voltage} - 16)}{.02} = R_{MAX}$$

For example, if the power supply voltage is 24 VDC, first subtract 16 VDC, then divide the remainder by .02.  $8/.02 = 400$ ; therefore, a 400 Ohm maximum load can be inserted into the loop with a 24 VDC power supply.

Similarly, the following values can be calculated:

Power Supply Voltage (VDC)	Total Load (Ohms)
16.0	0
20.0	200
24.0	400
30.0	700
35.0	950

#### 4.3 115/230 VAC w/Relays

In the 115/230 VAC configuration, a DC power supply is mounted into the inside rear of the enclosure. The power supply must be ordered with the proper operating voltage. Verify that the unit requires either 115 VAC or 230 VAC before installing. Also verify that power is fully disconnected before attempting to wire.

AC powered Q45 systems are supplied with 3 cable gland fittings and two ½” conduit adapters. One of the cable glands has a larger hole in the rubber gland and should be used for the power cord entry if a flexible power cord will be used for installation. One of the cable glands with the smaller gland opening should normally be used for the sensor cable. Cable glands and conduit hubs will screw into any of the three threaded holes on the bottom of the enclosure.

Connect HOT, NEUTRAL, and GROUND to the matching designations on terminal strip **TB5**.

## WARNING

**Disconnect line power voltage BEFORE connecting line power wires to Terminal TB5 of the power supply. The power supply accepts only standard three-wire single phase power. The power supply is configured for 115 VAC or 230 VAC operation at the factory at time of order, and the power supply is labeled as such. Do NOT connect voltages other than the labeled requirement to the input.**

The analog outputs from the system are present at terminals TB1 and TB2. The loop-load limitation in this configuration is 500 Ohms maximum for each output. Also note that these two outputs are completely isolated from each other to insure that ground loops do not result from the connection of both outputs to the same device such as a PLC or DCS.

In the line-powered unit, a ribbon cable connects the power supply assembly with the microprocessor assembly located in the front section of the enclosure. This cable can be removed during installation to facilitate wiring if desired. It is best to unplug only one end. The ribbon cable has a marking stripe on one edge that is used to indicate proper orientation. The indicator stripe should be on the bottom edge of the cable when installed as shown in Figure 4-2.

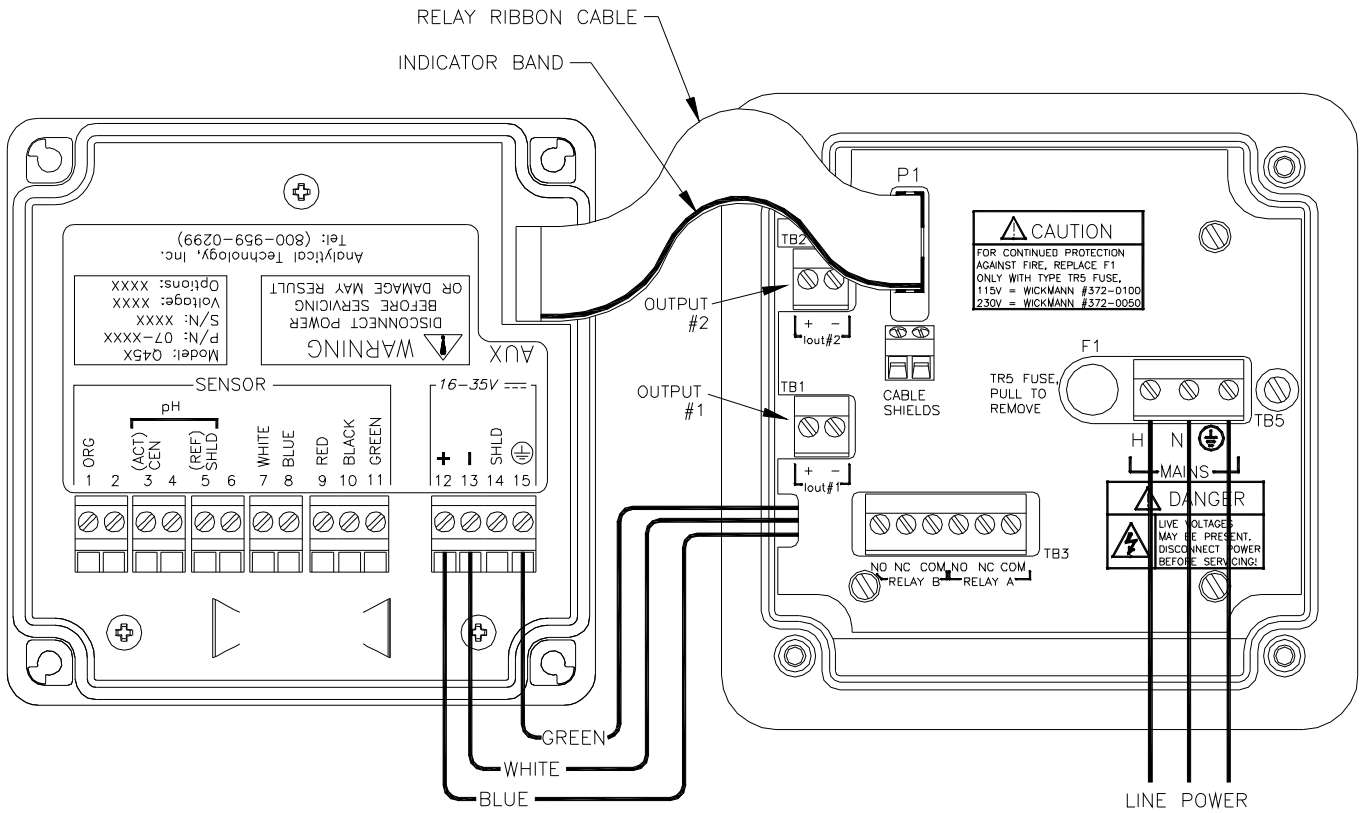

**Figure 4-2 Line Power Connection (ATI-0713)**

The power strip, **TB5**, allows up to 12 AWG wire. A wire gauge of 16 AWG is recommended to allow for an easy pass-through into the ½” NPT ports when wiring.

Two sets of SPDT relay contacts are provided on the power supply board. None of the relay contacts are powered. The user must supply the proper power to the contacts. For applications that require the same switched operating voltage as the Q45 (115 or 230 V), power may be jumpered from the power input terminals at **TB5**. Relay wiring is connected at **TB3** as shown below. Note that the relay contact markings are shown in the NORMAL mode. Programming a relay for “Failsafe” operation reverses the NO and NC positions in this diagram.

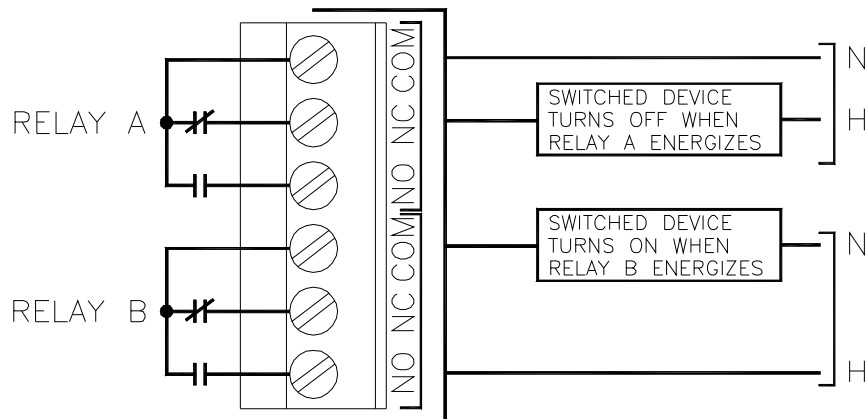

**Figure 4-3 Relay Contacts (ATI-0712)**

#### 4.4 Sensor Wiring

The sensor cable can be quickly connected to the Q45 terminal strip by matching the wire colors on the cable to the color designations on the label in the monitor. A junction box is also available to provide a break point for long sensor cable runs. Route signal cable away from AC power lines, adjustable frequency drives, motors, or other noisy electrical signal lines. Do not run sensor or signal cables in conduit that contains AC power lines or motor leads.

#### 4.5 Direct Sensor Connection

Sensor connections are made in accordance with Figure 4-1. The sensor cable can be routed into the enclosure through one of cord-grips supplied with the unit. Routing sensor wiring through conduit is only recommended if a junction box is to be used. Some loose cable is needed near the installation point so that the sensor can be inserted and removed easily from the flowcell.

Cord-grips used for sealing the cable should be snugly tightened after electrical connections have been made to prevent moisture incursion. When stripping cables, leave adequate length for connections in the transmitter enclosure as shown below. The standard 25 ft. sensor cable normally supplied with the system is already stripped and ready for wiring. This cable can be cut to a shorter length if desired to remove extra cable in a given installation. Do not cut the cable so short as to make installation and removal of the sensor difficult.

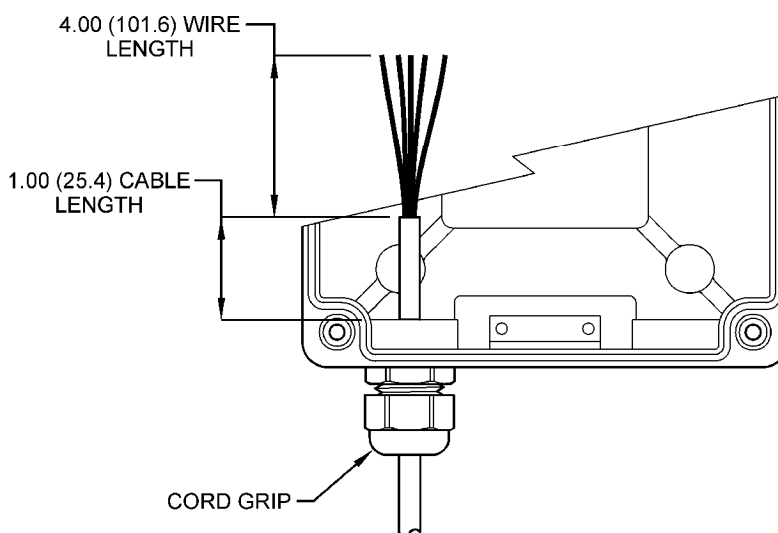

**Figure 4-4** *Sensor Cable Preparation*

### 4.6 Junction Box Connection

For installations where the sensor is to be located more than 25 feet from the monitor (max. 100 feet), a junction box must be used. The junction box is shown in Figure 4-5, and is supplied with a ½" conduit hub on one end and a sensor cable gland on the other end.

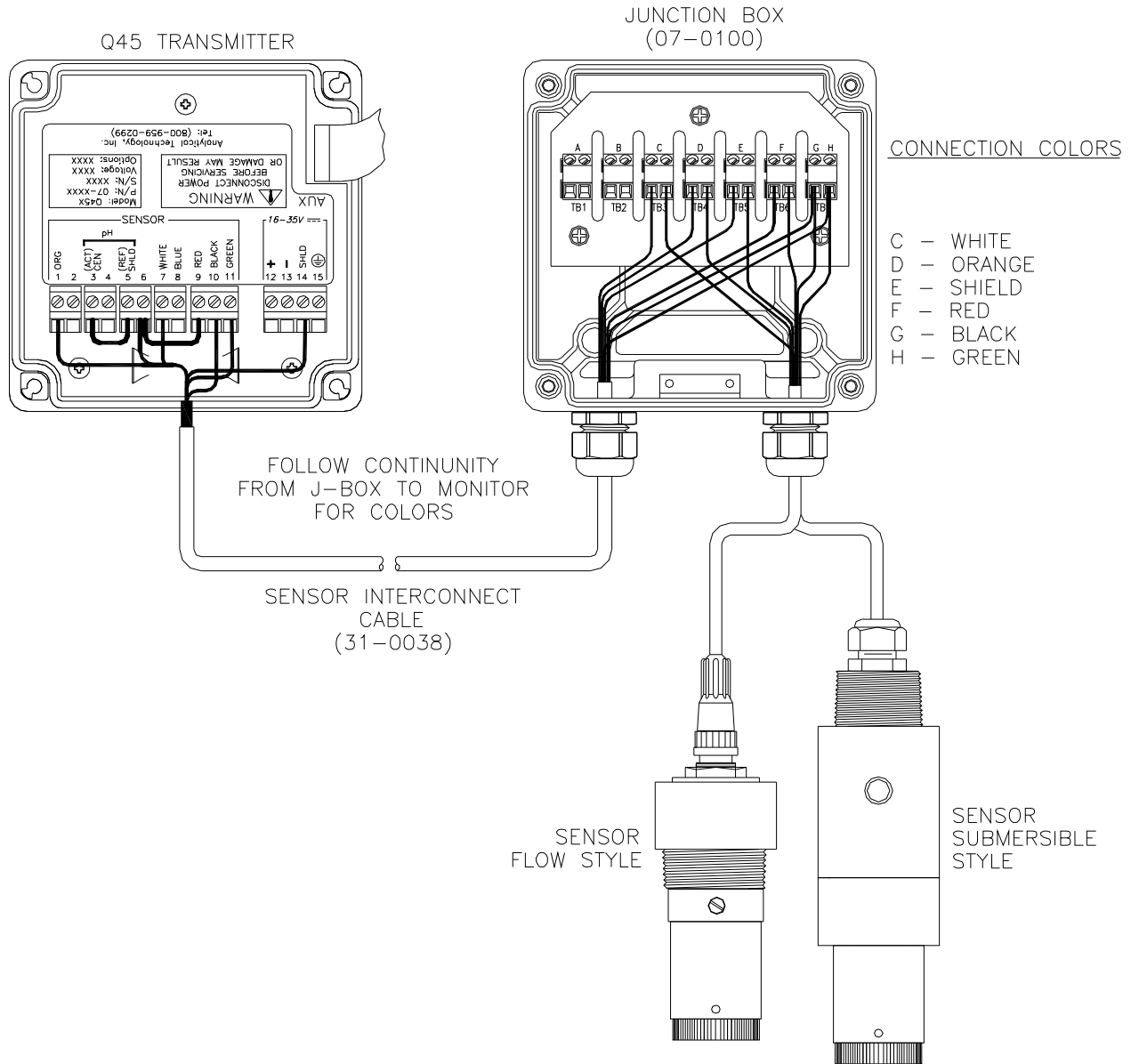

**Figure 4-5 Junction Box Interconnect Wiring (ATI-0714)**

#### 4.7 Optional pH Sensor Input

The Q45H may be configured for pH compensation to maintain excellent accuracy in applications where the pH can vary. To utilize the feature, a 0.3 – 1.5 VDC pH signal must be properly connected to terminals 5 and 6 of the instrument. The pH input for compensation can come from either a combination pH sensor, an ATI Q22 pH Sensor, or from the output of **another pH transmitter (see asterisk on next page)**. When using the input from a separate pH transmitter, input isolation is critical and an isolator may be required for proper operation. In addition, the pH input feature must be enabled, and the pH input signal must be properly calibrated and the correct pH Sensor Type selected in the Configuration Menu. Combination electrode Sensors, select Sensor Type #1, & ATI Q22P or pH 4-20 Transmitters select Sensor Type #2. Note that jumpers are installed at the factory between terminals 3 and 5, and terminals 6 and 9 when no pH sensor input is connected to reduce the potential for noise pickup. **Remove the jumpers if a pH sensor is added.** See diagram on the next page for sensor hook-up information.

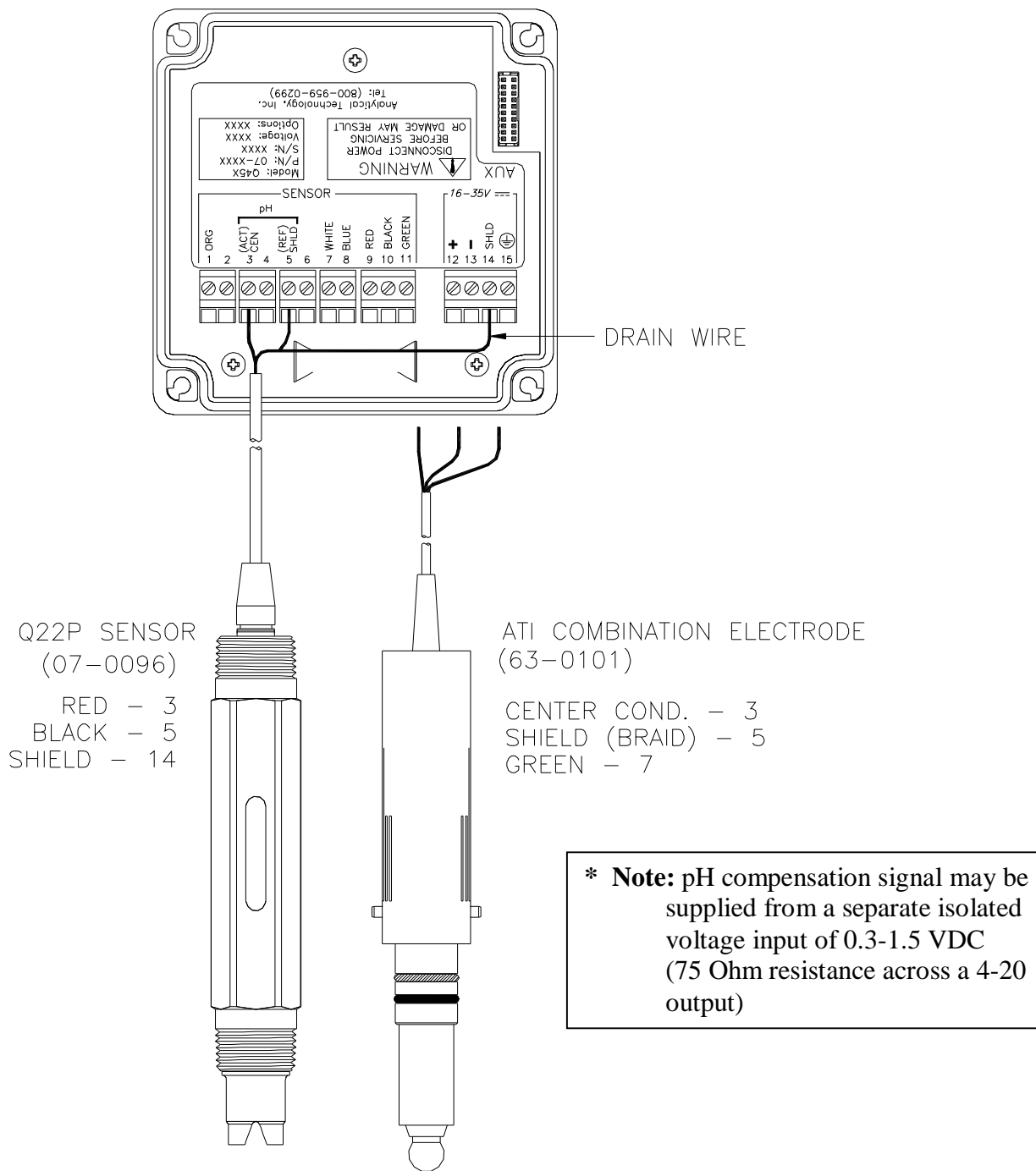

**Figure 4-6 Optional pH Sensor Connection (ATI-0660)**

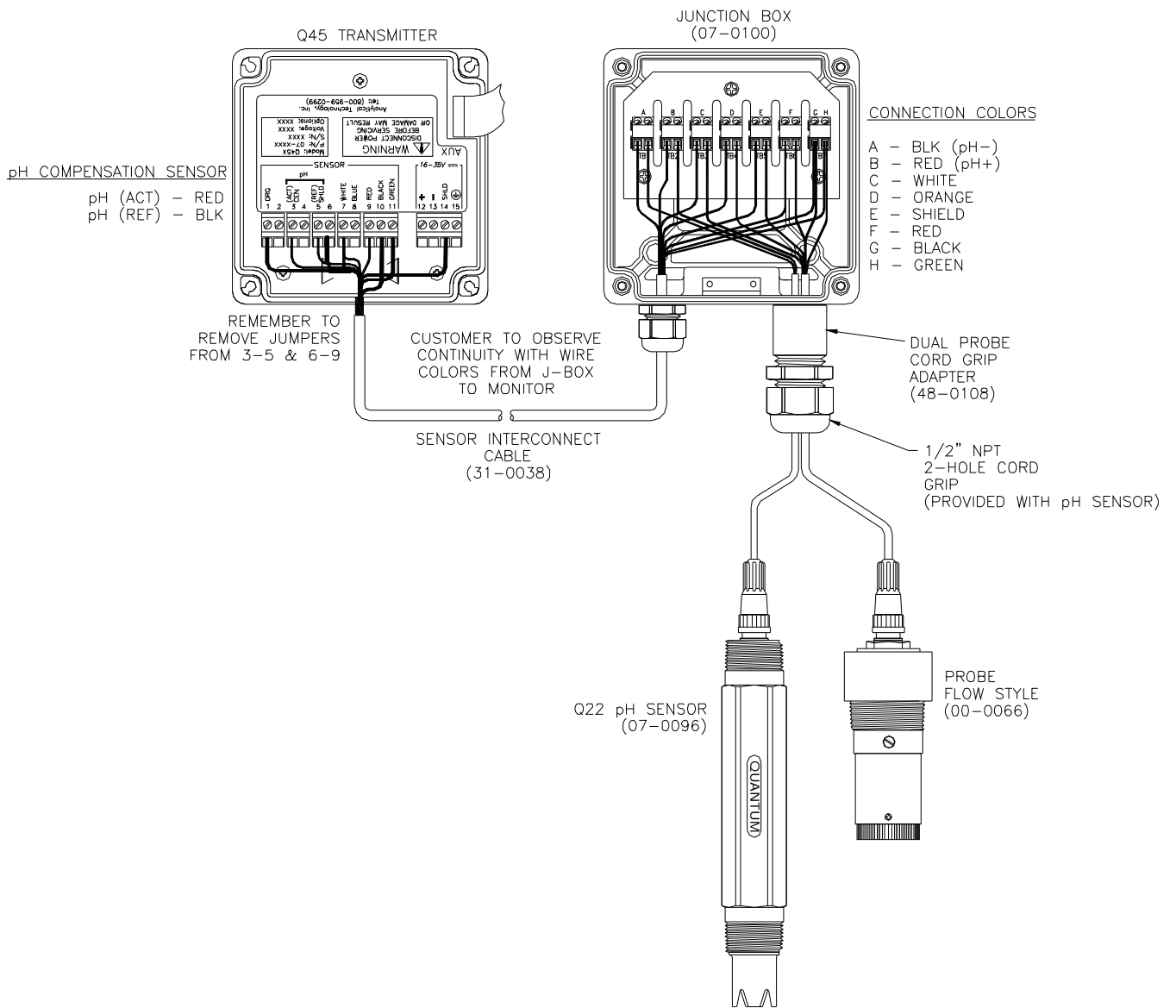
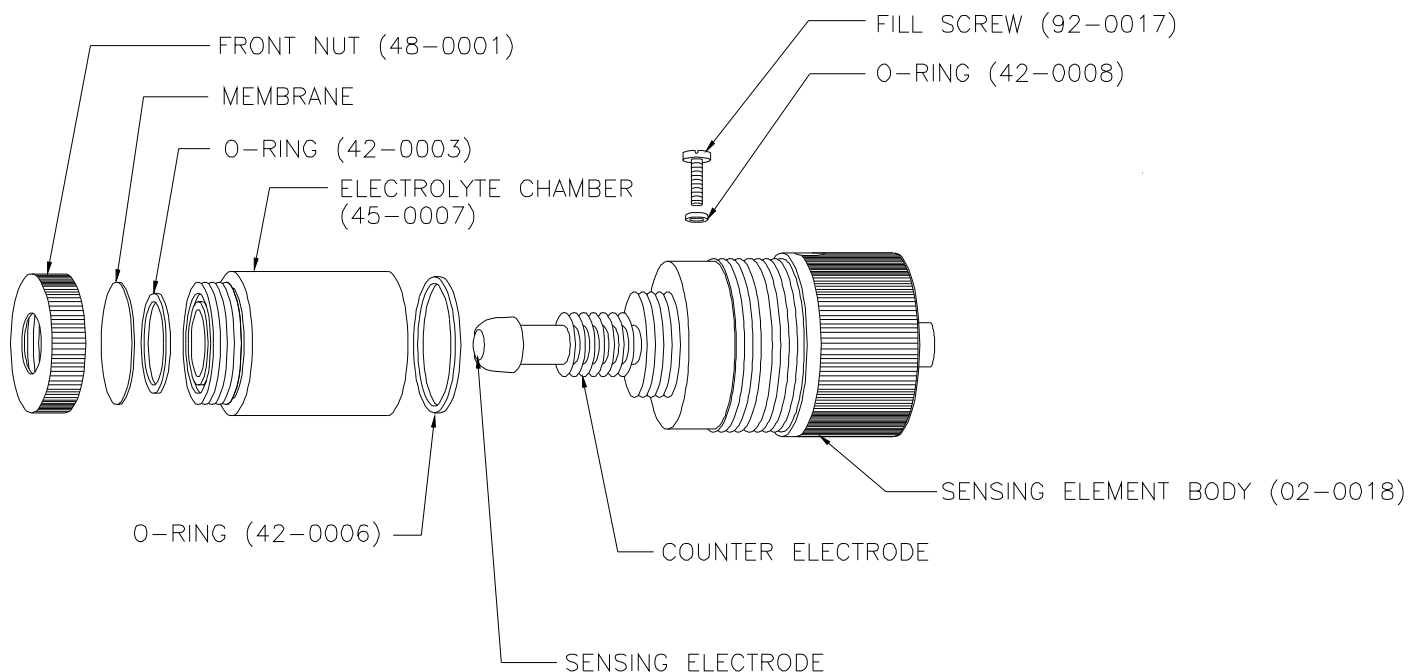

**Figure 4-7 Optional pH Sensor Connection w/Junction Box (ATI-0716)**

## Part 5 – Sensor Assembly

### 5.1 Ozone Sensor Preparation

The ozone sensor supplied with the Q45H is shipped dry. It will not operate until it is prepared by adding electrolyte and a membrane. Preparation of the sensor for operation must be done carefully. The procedure should be done by a qualified technician, and it should only be done when the system is ready for operation. Until then, it is best to leave the sensor in the condition in which it is received.



**Figure 5-1 Ozone Sensor Assembly (ATI-0294)**

Submersible ozone sensors are made up of two separate parts, a submersion holder that also contains the temperature compensating element and a sensing module. The sensing module screws into the holder, with an o-ring providing a water tight connection.

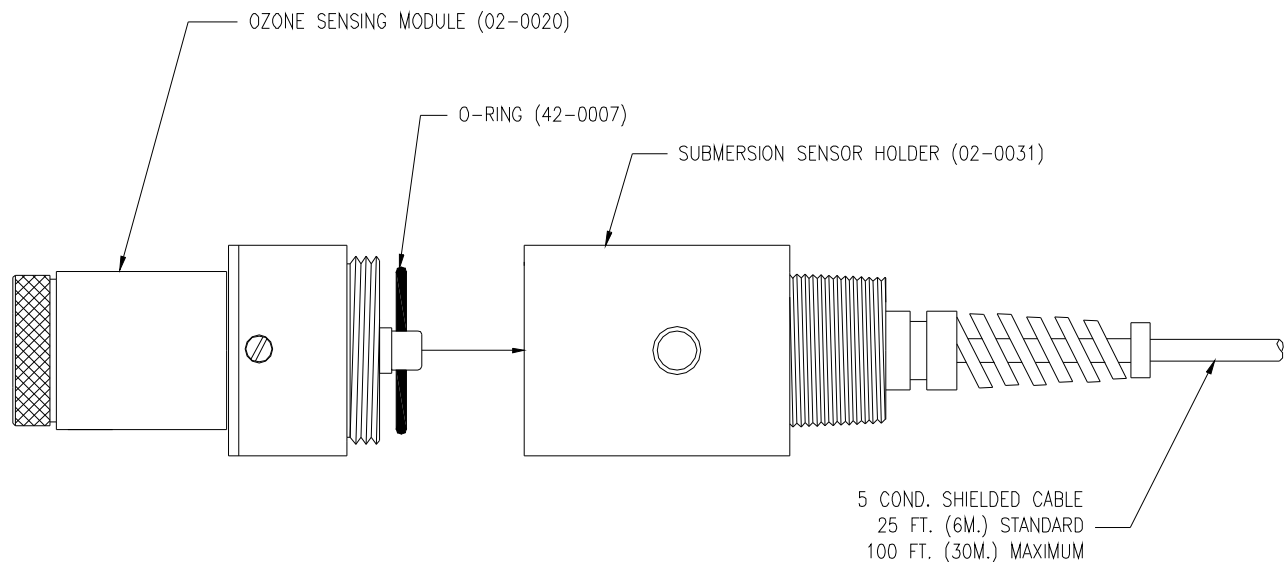

*Figure 5-2 Submersible Ozone Sensor Assembly*

Follow the procedure below to prepare the ozone sensor for operation:

1. Unscrew the electrolyte chamber from the assembled sensor and also remove the fill screw from the side of the sensor body.
2. Remove the front nut from the bottom of the chamber and discard the protective membrane. O-rings are contained in grooves on both the bottom and top of the chamber. Be sure that these o-rings remain in place.
3. From the package of membranes supplied with the sensor, place a new membrane into the front nut. **The membrane is white in color and is separated from other membranes by a light blue paper spacer.**
4. Screw the front nut on to the chamber until you feel the o-ring compress. Hand tight compression is all that is needed. Do not use tools to tighten. The membrane should be flat across the bottom of the chamber without wrinkles.

5. Fill the chamber with electrolyte until the level reaches the bottom of the internal threads.
6. Slowly screw the chamber onto the sensor body. A small amount of electrolyte will run out of the hole from which the fill screw was removed. Place a paper towel around the sensor to absorb the electrolyte overflow. The electrolyte is harmless and will not irritate skin. Tighten the chamber until the o-ring at the top of the chamber is compressed. Once again, do not use tools to tighten.
7. Shake excess electrolyte from the fill hole on the side of the sensor and replace the fill screw.

The sensor is now ready for operation. The membrane should be stretched tightly across the tip of the sensor.

**CAUTION:** When handling the assembled sensor, do not set the sensor on its tip or damage to the membrane will result. Severe impacts on the tip of the sensor from dropping or other misuse may cause permanent damage to the sensor.

## 5.2 Optional pH Sensor

An optional pH battery powered sensor is available for use with the Q45H system that outputs a nominal signal of 0.3-1.5 VDC proportional to pH over a range of 0-14 pH units. The Q22P is also available and outputs a standard 4-20 mA analog signal. Both sensors are shipped with a protective rubber boot containing a small amount of salt solution to keep the glass elements in good condition and ready for use.

No special preparations are required for use of this electrode. The protective boot should remain in place until the system is to be placed into continuous service. **Do not remove the protective boot and allow the sensor to sit in the air for an extended period of time. The pH electrodes MUST stay wet.**

When ready for operation, simply remove the rubber boot from the end of the sensor and place the sensor into the inlet chamber of the ozone overflow cell. It is placed directly above the sample inlet tube. You will need to slide the flowcell chamber cover out of the way to put the pH sensor in place.

# Part 6 – Configuration

## 6.1 User Interface

The user interface for the Q45 Series instrument consists of a custom display and a membrane keypad. All functions are accessed from this user interface (no internal jumpers, pots, etc.).

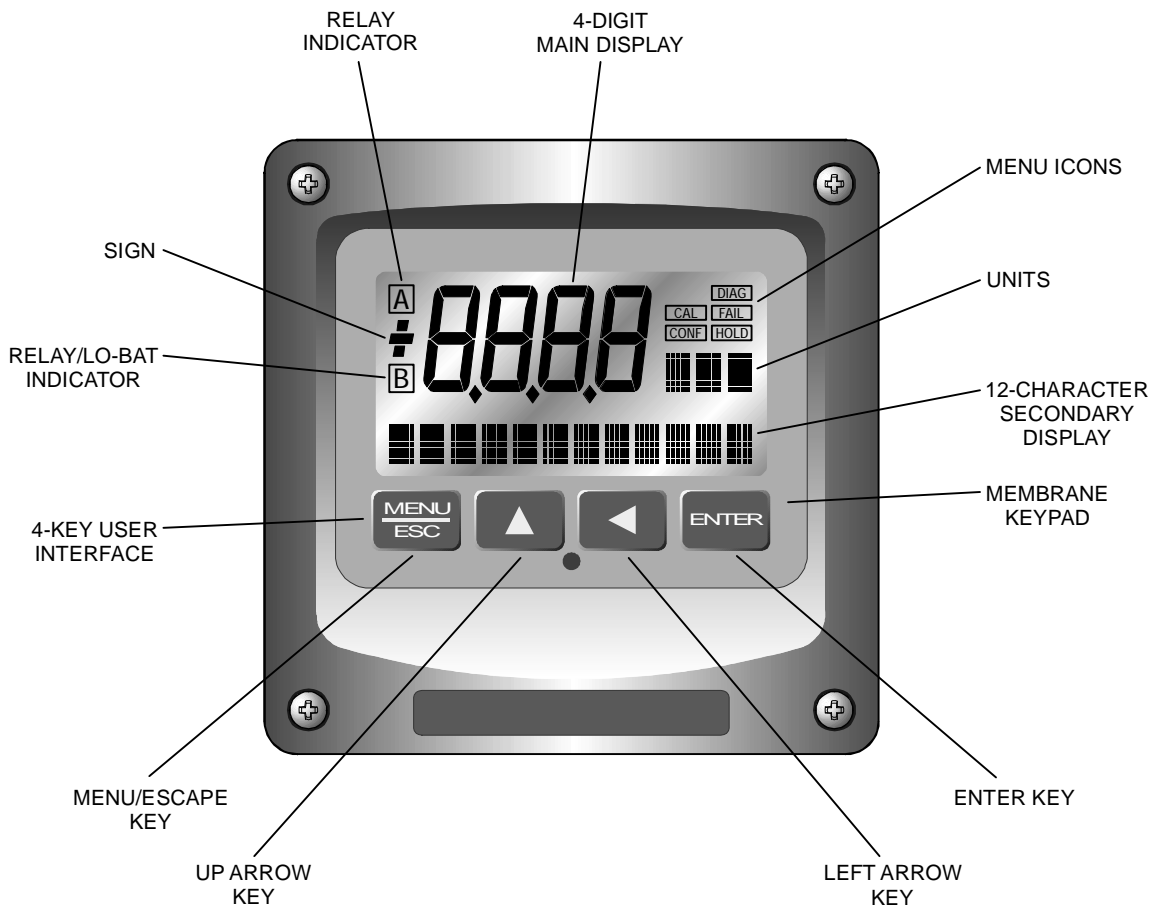

**Figure 6-1 User Interface (ATI-0654)**

## 6.11 Keys

All user configurations occur through the use of four membrane keys. These keys are used as follows:

- MENU/ESC** To scroll through the menu section headers or to escape from anywhere in software. The escape sequence allows the user to back out of any changes in a logical manner. Using the escape key aborts all changes to the current screen and backs the user out one level in the software tree. The manual will refer to this key as either MENU or ESC, depending upon its particular function. In the battery-powered version of the Q45, this is also the ON button.
- UP (arrow)** To scroll through individual list or display items and to change number values.
- LEFT (arrow)** To move the cursor from right to left during changes to a number value.
- ENTER** To select a menu section or list item for change and to store any change.

## 6.12 Display

The large custom display provides clear information for general measurement use and user configuration. There are three main areas of the display: the main parameter display, the secondary message line, and the icon area.

- Main Parameter** During normal operation, the main parameter display indicates the present process input with sign and units. This main display may be configured to display any of the main measurements that the system provides. During configuration, this area displays other useful set-up information to the user.

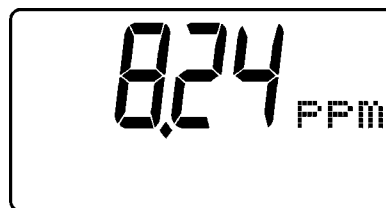

**Lower Line**

During normal operation, the lower line of the display indicates user-selected secondary measurements that the system is making. This also includes calibration data from the last calibration sequence and the transmitter model number and software version. During configuration, the lower line displays menu items and set-up prompts to the user. Finally, the lower line will display error messages when necessary. For a description of all display messages, refer to Section 10.4.

**Icon Area**

The icon area contains display icons that assist the user in set-up and indicate important states of system functions. The CAL, CONFIG, and DIAG icons are used to tell the user what branch of the software tree the user is in while scrolling through the menu items. This improves software map navigation dramatically. Upon entry into a menu, the title is displayed (such as CAL), and then the title disappears to make way for the actual menu item. However, the icon stays on.

**HOLD**

The HOLD icon indicates that the current output of the transmitter has been put into output hold. In this case, the output is locked to the last input value measured when the HOLD function was entered. HOLD values are retained even if the unit power is cycled.

**FAIL**

The FAIL icon indicates that the system diagnostic function has detected a problem that requires immediate attention. This icon is automatically cleared once the problem has been resolved.

## Relay Area A/B

The relay area contains two icons that indicate the state of the system relays (if the relay card is installed). If the battery board is installed instead, the B icon indicates that the battery voltage is at a low level. The battery power option and the relay option cannot be installed together.



## 6.2 Software

The software of the Q45H is organized in an easy to follow menu-based system. All user settings are organized under five menu sections: Measure, Calibration [CAL], Configuration [CONFIG], Control [CONTROL] and Diagnostics [DIAG].

**Note: The default Measure Menu is display-only and has no menu icon.**

### 6.2.1 Software Navigation

Within the CAL, CONFIG, CONTROL, and DIAG menu sections is a list of selectable items. Once a menu section (such as CONFIG) has been selected with the MENU key, the user can access the item list in this section by pressing either the ENTER key or the UP arrow key. The list items can then be scrolled through using the UP arrow key. Once the last item is reached, the list wraps around and the first list item is shown again. The items in the menu sections are organized such that more frequently used functions are first, while more permanent function settings are later in the list. See Figure 6-2 for a visual description of the software.

Each list item allows a change to a stored system variable. List items are designed in one of two forms: simple single variable, or multiple variable sequences. In the single variable format, the user can quickly modify one parameter - for example, changing temperature display units from °F to °C. In the multiple variable sequence, variables are changed as the result of some process. For example, the calibration of ozone generally requires more than one piece of information to be entered. The majority of the menu items in the software consist of the single variable format type.

Any data that may be changed will be flashing. This flashing indicates user entry mode and is initiated by pressing the ENTER key. The UP arrow key will increase a flashing digit from 0 to 9. The LEFT arrow key moves the flashing digit from right to left. Once the change has been completed, pressing ENTER again stores the variable and stops the flashing. Pressing ESC aborts the change and also exits user entry mode.

The starting (default) screen is always the Measure Menu. The UP arrow key is used to select the desired display. From anywhere in this section the user can press the MENU key to select one of the four Menu Sections.

The UP arrow icon next to all list items on the display is a reminder to scroll through the list using the UP arrow key.

To select a list item for modification, first select the proper menu with the MENU key. Scroll to the list item with the UP arrow key and then press the ENTER key. This tells the system that the user wishes to perform a change on that item. For single item type screens, once the user presses the ENTER key, part or all of the variable will begin to flash, indicating that the user may modify that variable using the arrow keys. However, if the instrument is locked, the transmitter will display the message **Locked!** and will not enter user entry mode. The instrument must be unlocked by entering the proper code value to allow authorized changes to user entered values. Once the variable has been reset, pressing the ENTER key again causes the change to be stored and the flashing to stop. The message **Accepted!** will be displayed if the change is within pre-defined variable limits. If the user decides not to modify the value after it has already been partially changed, pressing the ESC key aborts the modification and returns the entry to its original stored value.

In a menu item which is a multiple variable sequence type, once the ENTER key is pressed there may be several prompts and sequences that are run to complete the modification. The ESC key can always be used to abort the sequence without changing any stored variables.

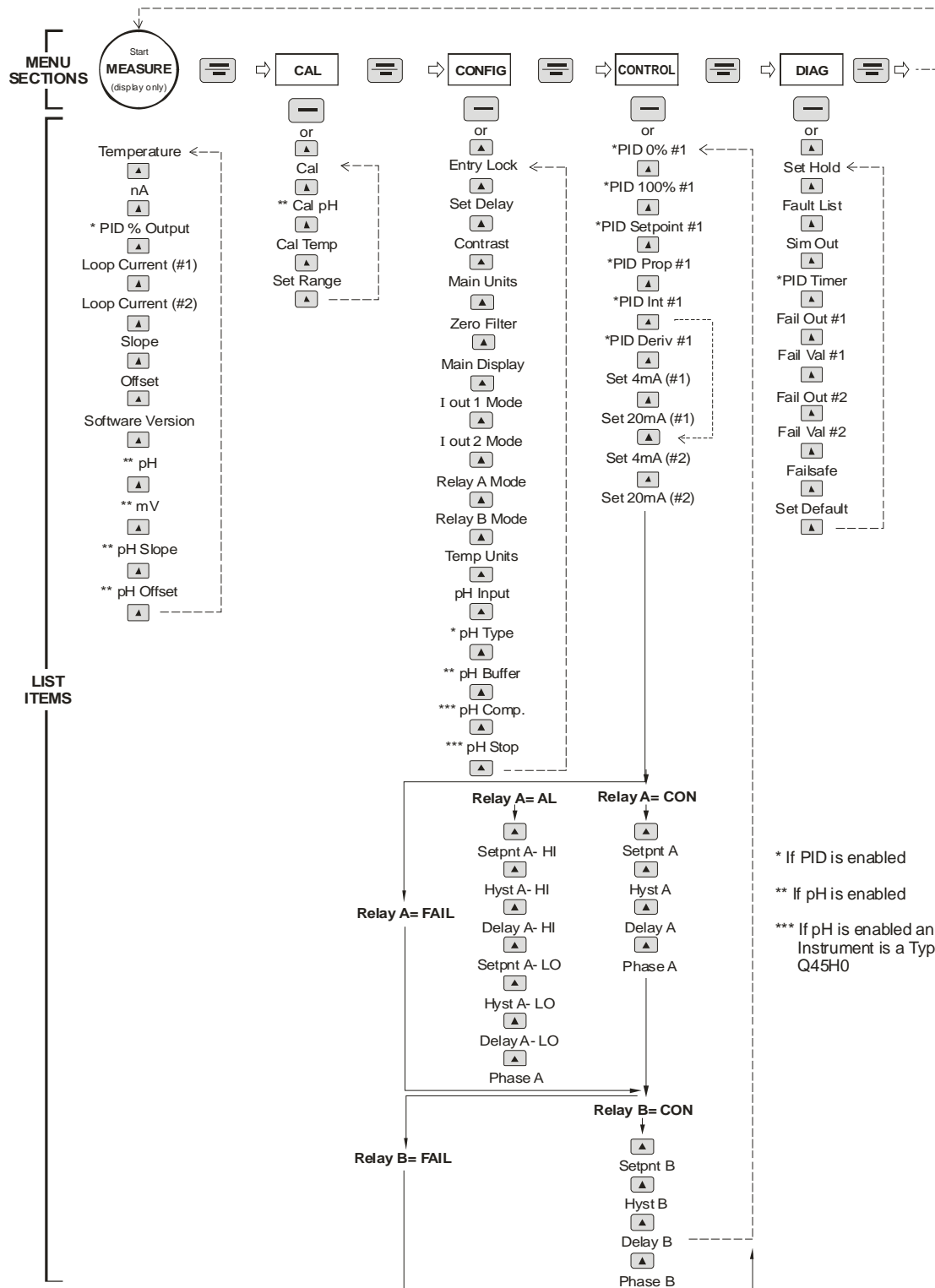

Figure 6-2 Software Map

## 6.22 Measure Menu [MEASURE]

The default menu for the system is the display-only menu MEASURE. This menu is a display-only measurement menu, and has no changeable list items. When left alone, the instrument will automatically return to this menu after approximately 30 minutes. While in the default menu, the UP arrow allows the user to scroll through the secondary variables on the lower line of the display. A brief description of the fields in the basic transmitter version is as follows:

### TRANSMITTER MEAS SCREENS:

<b>25.7C</b>	Temperature display. Can be displayed in C or F, depending on user selection. A small “m” on the left side of the screen indicates the transmitter has automatically jumped to a manual 25C setting due to a failure with the temperature signal input.
<b>32.0 nA</b>	Raw sensor current. Useful for diagnosing problems.
<b>100% 20.00 mA</b>	PID Status screen (if enabled.) Shows the present controller output level on left, and actual transmitter current on the right. The controller can be placed in manual while viewing this screen by pressing and holding the ENTER key for 5 seconds until a small flashing “m” appears on the screen. At that point the controller output can be adjusted up or down using the UP and LEFT arrow keys. To return to automatic operation, press and hold the ENTER key for 5 seconds and the “M” will disappear.
<b>4.00 mA</b>	Transmitter output current # 1
<b>20.00 mA</b>	Transmitter output current # 2
<b>Slope = 100%</b>	Sensor output response vs. ideal calibration. This value updates after each calibration. As the sensor ages, the slope reading will decay indicating sensor aging. Useful for resolving sensor problems.
<b>Offset = 0.0 nA</b>	Sensor output current at a zero ppm input. This value updates after a zero-calibration has been performed. Useful for resolving sensor problems.
<b>Q45H0 v 4.02</b>	Transmitter software version number.

**Note: A display test (all segments ON) can be actuated by pressing and holding the ENTER key while viewing the model/version number on the lower line of the display.**

<b>7.56 pH</b>	Measured pH value on AUX input (if enabled.)
<b>5.00 mV</b>	pH sensor mV output (if enabled)
<b>Slope = 100%</b>	pH sensor slope response vs. ideal calibration. This value will update after each calibration. As the pH sensor ages, the slope reading will decay. This is useful for solving sensor problems (if enabled).
<b>Offset = X.X mV</b>	pH sensor current output at 7 pH input. This value updates after calibration is performed and is useful for resolving sensor problems.

For the relay-based analyzer version, or the portable battery powered version of the transmitter, the screens are basically the same, with additions to show two analog output instead of one (#1 and #2.)

The MEASURE screens are intended to be used as a very quick means of looking up critical values during operation or troubleshooting.

### 6.23 Calibration Menu [CAL]

The calibration menu contains items for frequent calibration of user parameters. There are four items in this list: Cal Ozone, Cal Temp, Set Range, and Cal Zero.

**Cal O<sub>3</sub>** The ozone calibration function allows the user to adjust the transmitter span reading to match a reference solution, or to set the sensor zero point. See Part 7 - Calibration for more details.

**Cal pH (if enabled)** The pH calibration function allows the user to adjust the transmitter offset and span to match the sample or reference buffers. See Part 7 – Calibration for more details.

**Cal Temp** The temperature calibration function allows the user to adjust the offset of the temperature response by a small factor of  $\pm 5$  °C. The temperature input is factory calibrated to very high accuracy. However, long cable lengths and junction boxes may degrade the accuracy of the temperature measurement in some extreme situations. Therefore, this

feature is provided as an adjustment. See Part 7 - Calibration for more details.

### **Set Range**

This function allows the user to set the display range of the transmitter to a specific application. Once set, all output functions use this display range to establish configuration settings. Press ENTER to initiate user entry mode, and the value will flash. Use the arrow keys to modify value; available ranges include 200.0 ppb, 2.000 ppm, 20.00 ppm, and 200.0 ppm. Press ENTER to store the new value. The display range does not affect the internal auto ranging scaler that, therefore, sensitivity is to specification in any user selected range.

## **6.24 Configuration Menu [CONFIG]**

The Configuration Menu contains all of the general user settings:

### **Entry Lock**

This function allows the user to lock out unauthorized tampering with instrument settings. All settings may be viewed while the instrument is locked, but they cannot be modified. The Entry Lock feature is a toggle-type setting; that is, entering the correct code will lock the transmitter and entering the correct code again will unlock it. The code is preset at a fixed value. Press ENTER to initiate user entry mode and the first digit will flash. Use arrow keys to modify value. **See end of manual for the Q45H lock/unlock code.** Press ENTER to toggle lock setting once code is correct. Incorrect codes do not change state of lock condition.

### **Set Delay**

The delay function sets the amount of damping on the instrument. This function allows the user to apply a first order time delay function to the ozone measurements being made. Both the display and the output value are affected by the degree of damping. Functions such as calibration are not affected by this parameter. The calibration routines contain their own filtering and stability monitoring functions to minimize the calibration timing. Press ENTER to initiate user entry mode, and the value will flash. Use the arrow keys to modify value; range is 0.1 to 9.9 minutes. Press ENTER to store the new value.

- Contrast** This function sets the contrast level for the display. The custom display is designed with a wide temperature range, Super-Twist Nematic (STN) fluid.
- The STN display provides the highest possible contrast and widest viewing angle under all conditions. Contrast control of this type of display is generally not necessary, so contrast control is provided as a means for possible adjustment due to aging at extreme ranges. In addition, the display has an automatic temperature compensation network. Press ENTER to initiate user entry mode, and the value will flash. Use arrow keys to modify the value; range is 0 to 8 (0 being lightest). Press ENTER to update and store the new value.
- Main Units** This function allows the user to select either PPM or mg/l for the dissolved ozone measurement.
- Zero Filter** This function forces the reading to zero when reading is below the entered value. For example, if the entered value were 0.0020 the display at 0-0019 would indicate 0.000. This feature is useful in blanking out zero noise.
- Main Display** This function allows the user to change the measurement in the primary display area. The user may select between ozone, sensor temperature, or output current. Using this function, the user may choose to put temperature in the main display area and ozone on the secondary, lower line of the display. Press ENTER to initiate user entry mode, and the entire value will flash. Use the UP arrow key to modify the desired display value. Press ENTER to store the new value.
- lout#1 Mode** This function sets analog output #1 to either track ozone (default) or enables the PID controller to operate on the ozone input. Press ENTER to initiate user entry mode, and the entire value will flash. Use the UP arrow key to modify the desired value; selections include 1-ppm for ozone tracking or 2-PID for ozone PID control. Press ENTER to store the new value.

#### **AC OPERATED UNITS ONLY**

- \*lout#2 Mode** This function sets analog output #2 for temperature (default), ozone, or pH. Press ENTER to initiate user entry mode, and the entire value will flash. Use the UP arrow key to modify the desired value; selections include 1-C/F for temperature, 2-ppm for ozone, or 3-pH for pH. Press ENTER to store the new value.

**AC OPERATED UNITS ONLY****\*Rly A Mode**

Relay A can be used in three different ways: as a setpoint control, as a fail alarm, or as a HI-LO alarm band. The three settings for Rly A Mode are **CON**, **FAIL** and **AL**.

The **CON** setting enables normal control operation for Relay A, with settings for setpoint, hysteresis, delay and phasing appearing in the CONFIG menu automatically. See Figure 6-3 for further details.

The **FAIL** setting enables the fail alarm mode for Relay A. Relay A will then trip on any condition that causes the FAIL icon to be displayed on the LCD. Using this mode allows the User to send alarm indications to other remote devices.

The **AL** setting allows two setpoints to be selected for the same relay, producing a HI-LO alarm band. In this mode, Relay A will trip inside or outside of the band, depending upon the Phase selected. See Figure 6-4 for further details.

**AC OPERATED UNITS ONLY****\*Relay B Mode**

Relay B can be used in a number of ways: as a setpoint control, or as an alarm. The two settings for Relay B Mode are **CON** and **FAIL**.

The **CON** setting enables normal setpoint operation for Relay B. Relay B then operates identically to Relay A, with settings for setpoint, hysteresis, delay and phasing appearing in the CONFIG menu automatically. See Figure 6-3 for details.

The **FAIL** setting enables the fail alarm mode for Relay B. Relay B will then trip on any condition that causes the FAIL icon to be displayed on the LCD. Using this mode allows the User to send alarm indications to other remote devices. See Figure 6-4 for details.

**Temp Units**

This function sets the display units for temperature measurement. Press ENTER to initiate user entry mode, and the entire value will flash. Use the UP arrow key to modify the desired display value. The choices are °F and °C. Press ENTER to store the new value.

- pH Input** Enables the auxiliary pH input on the instrument. Once enabled, an optional pH sensor can be added to the instrument to provide for additional monitoring of pH (dual instrument, ozone + pH output.)
- For the relay-based analyzer with two analog outputs, the pH signal can also be sent to one of the analog outputs for monitoring of pH. Once enabled, the pH input value is displayed on the lower line of the MEASURE screens. Press ENTER to initiate user entry mode, and the entire value will flash. Use the UP arrow key to modify the desired display value. The choices are **OFF** and **ON**. Press ENTER to store the new value.
- pH Type** Allows the user to select either 1-Comb or 2-Q22P. The 1-Comb selection configures the monitor for a standard pH electrode without using its temperature compensation but in turn, uses the temperature compensator from the ozone sensor. The 2-Q22P selection configures the monitor for use with the Q22P sensor or for the 4-20 mA input from any other pH monitor.
- pH Buffer** This turns on and off the automatic pH recognition feature.
- pH Comp** Enables pH compensation of free chlorine measurements using a built in comp table and is turned off and not used with the dissolved ozone measurement
- Comp Stop** This feature allows the user to halt the internal pH compensation curve at a user-defined pH point. This point is intended to be 9 pH or greater. The pH compensation function will follow the internal curve up until the pH reaches this point. Once at this point, the compensation factor value will hold at the last value of the curve. This effectively "dog-legs" the response. In application, the user would set the stop value in an attempt to correct over-compensation problems that only appear to be a problem at very high pH values. Press ENTER to initiate user entry mode, and the entire value will flash. Use the UP arrow key to modify the desired display value. The range in value is from 8.00 to 14.00 pH. Leave value at 10.00 pH for most cases. Press ENTER to store the new value. See Part 7 - Calibration for more details.

## 6.25 Control Menu [CONTROL]

The Control Menu contains all of the output control user settings:

### Set 4 mA

### Set 20 mA

[lout1=ozone]

These functions set the main 4 and 20 mA current loop output points for the transmitter. The units displayed depend on the selection made in the CONFIG menu for lout #1 Mode. Also, when the Relay Option Board is installed, the units will also display **#1 or #2** – since there are actually two analog outputs present in this version.

The value stored for the 4 mA point may be higher or lower than the value stored for the 20 mA point. The entry values are limited to values within the range specified in “Set Range”, and the 4 mA and the 20 mA point must be separated by at least 1% of this range. Use the LEFT arrow key to select the first digit to be modified. Then use the UP and LEFT arrow keys to select the desired numerical value. Press ENTER to store the new value.

### Set PID 0%

### Set PID 100%

[lout1=PID]

If the PID is enabled, this function sets the minimum and maximum controller end points. Unlike the standard 4-20 mA output, the controller does not “scale” output values across the endpoints. Rather, the endpoints determine where the controller would normally force minimum or maximum output in an attempt to recover the setpoint (even though the controller can achieve 0% or 100% anywhere within the range.)

If the 0% point is lower than the 100% point, then the controller action will be “reverse” acting. That is, the output of the controller will increase if the measured value is less than the setpoint, and the output will decrease if the measured value is larger than the setpoint. Flipping the stored values in these points will reverse the action of the controller to “direct” mode.

The entry value is limited to a value within the range specified in “Set Range”, and the 0% and the 100% point must be separated by at least 1% of this range. Use the LEFT arrow key to select the first digit to be modified. Then

use the UP and LEFT arrow keys to select the desired numerical value. Press ENTER to store the new value.

**PID Setpnt**

[Iout1=PID]

The measured value which the controller is attempting to maintain by adjusting output value. It is the nature of the PID controller that it never actually gets to the exact value and stops. The controller is continually making smaller and smaller adjustments as the measured value gets near the setpoint.

**PID Prop**

[Iout1=PID]

Proportional gain factor. The proportional gain value is a multiplier on the controller error (difference between measured value and setpoint value.) Increasing this value will make the controller more responsive.

**PID Int**

[Iout1=PID]

Integral is the number of “repeats-per-minute” of the action of the controller. It is the number of times per minute that the controller acts on the input error. At a setting of 2.0 rpm, there are two repeats every minute. If the integral is set to zero, a fixed offset value is added to the controller (manual reset.) Increasing this value will make the controller more responsive.

**PID Deriv**

[Iout1=PID]

Derivative is a second order implementation of Integral, used to suppress “second-order” effects from process variables. These variables may include items like pumps or mixers that may have minor impacts on the measured value. The derivative factor is rarely used in water treatment process, and therefore, it is best in most cases to leave it at the default value. Increasing this value will make the controller more responsive.

**AC POWERED UNITS ONLY****\*Set 4 mA #2****\*Set 20 mA #2**

[temp/ozone/pH]

These functions set the second 4 mA and 20 mA current loop output points for the transmitter. The output may be set to track temperature (default), pH, or ozone. The values stored for the 4 mA point may be higher or lower than the value stored for the 20 mA point.

The entry value is limited to a value between 0° and 55°C if it is set for temperature, within the range specified in “Set Range” if the output is set to track ozone, and must be within 0-14 pH if set to track pH. The 4 mA and the 20 mA point must be at least 20 units away from each other. Press ENTER to initiate user entry mode, and the value will flash. Use arrow keys to modify value. Press ENTER to store the new value.

*NOTE:* If the temperature units are changed between °C and °F (see Temp Units in this section), the default settings for this output will be stored (present data is not converted.)

*NOTE:* If the battery board option is installed, the menu will be shown as **Set 0 V #2** – since the battery board has two 0-2.5 VDC voltage output signals instead of current outputs.

#### **ALARM CONFIGURATIONS APPLY TO AC POWERED UNITS ONLY**

- \*A Setpoint** This function establishes the ozone trip point for relay A. The entry value is limited to a value within the range specified in “Set Range”. Use the LEFT arrow key to select the first digit to be modified. Then use the UP and LEFT arrow keys to select the desired numerical value. Press ENTER to store the new value.
- \*A Hysteresis** This function establishes the hysteresis, or “deadband”, for Relay A. Hysteresis is most often used to control relay chattering; however, it may also be used in control schemes to separate the ON/OFF trip points of the relay. Press ENTER to initiate user entry mode, and the value will flash. Use the arrow keys to modify value. Press ENTER to store the new value.
- \*A Delay** This function places an additional amount of time delay on the trip point for relay A. This delay is in addition to the main delay setting for the controller. The entry value is limited to a value between 0 and 999 seconds. Press ENTER to initiate user entry mode, and the value will flash. Use arrow keys to modify value; range is 0 to 999 seconds. Press ENTER to store the new value.
- \*A Phasing** This function establishes the direction of the relay trip. When phase is HI, the relay operates in a direct mode. Therefore, the relay energizes and the LCD indicator

illuminates when the ozone value **exceeds** the setpoint. When the phase is LO, the relay energizes and the LCD indicator illuminates when the ozone level drops **below** the setpoint. The failsafe setting does have an impact on this logic. The description here assumes the failsafe setting is OFF. Press ENTER to initiate user entry mode, and the entire value will flash. Use the UP arrow key to modify the desired value; selections include **HI** for direct operation or **LO** for reverse operation. Press ENTER to store the new value.

**NOTE:** If the temperature units are changed between °C and °F (see Temp Units in this section), the default setting for this output will change between 100 °C and 212 °F accordingly.

See Figure 6-3 below for a visual description of a typical control relay application.

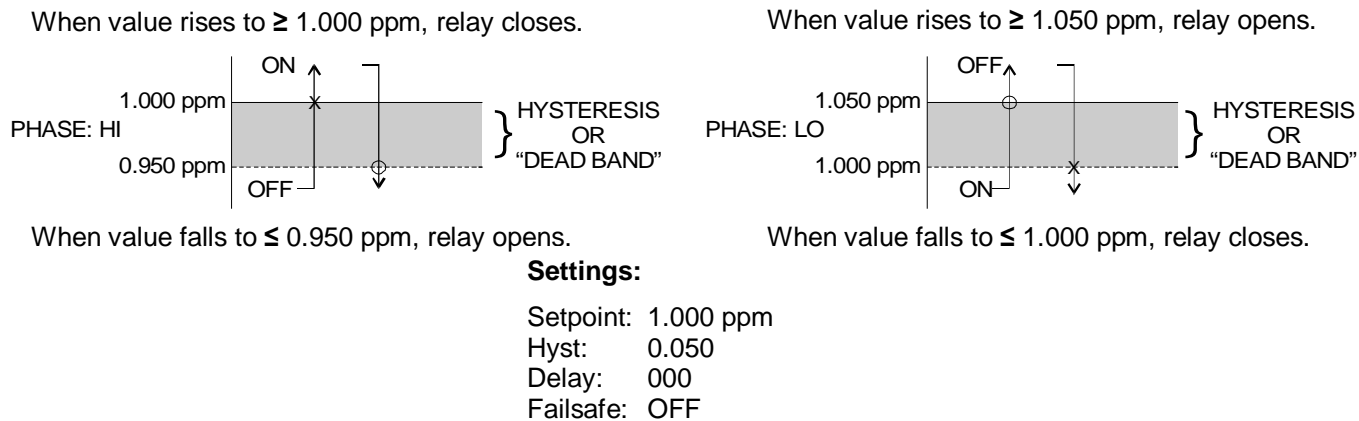
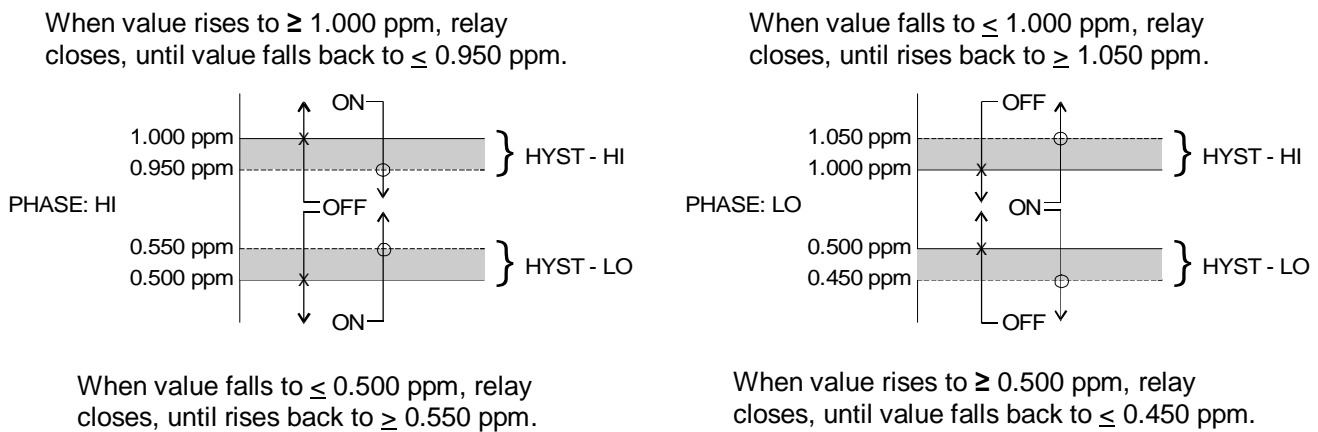

**Figure 6-3 Control Relay Example, Hysteresis and Two Opposite Phase Options**

- \*Setpnt A-HI
- \*Hyst A-HI
- \*Delay A-HI
- \*Setpnt A-LO
- \*Hyst A-LO
- \*Delay A-LO

If Relay A Mode is set to Alarm Mode, **AL**, then the following settings will appear in the Config Menu list automatically. In this mode, two setpoints can be selected on the same relay, to create an alarm band. Phase HI selection causes the relay to energize outside of the band, and Phase LO causes the relay to energize inside of the band. This feature enables one relay to be used as a control relay while the other is used as a HI-LO Alarm relay at the same time. Setpoint A-LO must be set lower than Setpoint A-HI. When AL mode is first selected, Setpoint A-LO is defaulted to 0.

Figure 6-4 is a visual description of a typical alarm relay application.



**Settings:**

Setpoint	A-HI: 1.000 ppm	Setpoint	A-LO: .500 ppm
Hyst	A-HI: 0.050	Hyst	A-LO: .0.050
Delay	A-HI: 000	Delay	A-LO: 000

**Figure 6-4 Alarm Relay Example**

- \*B Setpoint
- \*B Hysteresis
- \*B Delay
- \*B Phasing

If Relay B Mode is set to **CON** (see **Relay B Mode**), then Relay B will function identically to Relay A. Relay B settings appear in the CONFIG menu list automatically.

## 6.26 Diagnostics Menu [DIAG]

The diagnostics menu contains all of the user settings that are specific to the system diagnostic functions, as well as functions that aid in troubleshooting application problems.

### Set Hold

The Set Hold function locks the current loop output values on the present process value and halts operation of the PID controller. This function can be used prior to calibration, or when removing the sensor from the process, to hold the output in a known state. Once HOLD is released, the outputs return to their normal state of following the process input. The transfer out of HOLD is bumpless on the both analog outputs - that is, the transfer occurs in a smooth manner rather than as an abrupt change. An icon on the display indicates the HOLD state, and the HOLD state is retained even if power is cycled. Press ENTER to initiate user entry mode, and entire value will flash. Use the UP arrow key to modify the desired value, selections are **ON** for engaging the HOLD function, and **OFF** to disengage the function. Press ENTER to store the new value.

**Note:** When the Relay Option Board is installed, the Set Hold function holds BOTH current levels, as well as ALL relay settings.

The Set Hold function can also hold at an output value specified by the user. To customize the hold value, first turn the HOLD function on. Press the ESC key to go to the DIAG Menu and scroll to Sim Output using the UP arrow key. Press ENTER. Follow the instructions under Sim Output (see following page).

### Fault List

The Fault List screen is a read-only screen that allows the user to display the cause of the highest priority failure. The screen indicates the number of faults present in the system and a message detailing the highest priority fault present. Note that some faults can result in multiple displayed failures due to the high number of internal tests occurring. As faults are corrected, they are immediately cleared.

Faults are not stored; therefore, they are immediately removed if power is cycled. If the problem causing the faults still exists, however, faults will be displayed again after power is re-applied and a period of time elapses during which the diagnostic system re-detects them. The exception to this rule is the calibration failure. When a calibration fails, no corrupt data is stored. Therefore, the system continues to function normally on the data that was present before the calibration was attempted.

After 30 minutes or if power to the transmitter is cycled, the failure for calibration will be cleared until calibration is attempted again. If the problem still exists, the calibration failure will re-occur. Press ENTER to initiate view of the highest priority failure. The display will automatically return to normal after a few seconds.

### **PID Timer**

This function sets a timer to monitor the amount of time the PID controller remains at 0% or 100%. This function only appears if the PID controller is enabled. If the timer is set to 0000, the feature is effectively disabled. If the timer value is set to any number other zero, a FAIL condition will occur if the PID controller remains at 0% or 100% for the timer value. If one of the relays are set to FAIL mode, this failure condition can be signaled by a changing relay contact.

Press ENTER to initiate user entry mode, and the entire value will flash. Use the UP arrow key to modify desired value; range of value is 0-9999 seconds. Press ENTER to store the new value.

### **Sim Out**

The Sim Out function allows the user to simulate the ozone level of the instrument in the user selected display range. The user enters a ppm value directly onto the screen, and the output responds as if it were actually receiving the signal from the sensor. This allows the user to check the function of attached monitoring equipment during set-up or troubleshooting. Escaping this screen returns the unit to normal operation. Press ENTER to initiate the user entry mode, and the right-most digit of the value will flash. Use arrow keys to modify desired value.

The starting display value will be the last read value of the input. The output will be under control of the SIM screen until the ESC key is pressed.

*Note:* If the HOLD function is engaged before the Sim Output function is engaged, the simulated output will remain the same even when the ESC key is pressed. Disengage the HOLD function to return to normal output.

### **Fail Out**

This function enables the user to define a specified value that the main current output will go to under fault conditions. When the Relay Option Board is installed, the display will read **Fail Out #1**. When enabled to **ON**, the output may be forced to the current value set in **Fail Val** (next item.) With the Fail Out setting of **ON**, and a Fail Val setting of 6.5 mA, any alarm condition will cause the current loop output to drop outside the normal operating range to exactly 6.5 mA, indicating a system failure that requires attention.

Press ENTER to initiate user entry mode, and the entire value will flash. Use the UP arrow key to modify desired value; selections are **ON**, **OFF**. Press ENTER to store the new value.

### **Fail Val**

Sets the output failure value for lout#1. When **Fail Out** above is set to **ON**, this function sets value of the current loop under a FAIL condition. When the Relay Option Board is installed, the display will read **Fail Out #1**. The output may be forced to any current value between 4-20 mA.

Press ENTER to initiate user entry mode, and the entire value will flash. Use the UP arrow key to modify desired value; selections are between **4mA**, and **20mA**. Press ENTER to store the new value.

## **AC POWERED UNITS ONLY**

### **Fail Out #2**

This function sets the fail-mode of current loop output #2 under a FAIL condition. The settings and operation are identical to Fail Out for output #1.

### **Fail Val #2**

This function sets the value of current loop output #2 under a FAIL condition. The settings and operation are identical to Fail Out for output #1.

**AC POWERED UNITS ONLY****\*Failsafe**

This function allows the user to set the optional system relays to a failsafe condition. In a failsafe condition, the relay logic is reversed so that the relay is electrically energized in a normal operating state. By doing this, the relay will not only change state when, for example, an ozone limit is exceeded, but also when power is lost to the controller.

When failsafe is selected to be ON, the normally-open contacts of the relay will be closed during normal operation. In an attempt to make this configuration less confusing, the LCD icon logic is reversed with this setting, and the icon is OFF under this normal condition. Therefore, when the trip condition occurs, the closed N.O. contacts will be opened (relay de-energized), and the LCD icon will illuminate. In addition, a power fail would also cause the same contacts to open.

**Set Default**

The Set Default function allows the user to return the instrument back to factory default data for all user settings or for just the calibration default. It is intended to be used as a last resort troubleshooting procedure. All user settings or the calibration settings are returned to the original factory values. Hidden factory calibration data remains unchanged. Press ENTER to initiate user entry mode and the value **NO** will flash. Use the UP arrow key to modify value to **YES** and press ENTER to reload defaults.

# Part 7 – Calibration

---

## 7.1 Ozone Calibration

Once power is applied, the sensor must be given time to stabilize. This is best done by following the zeroing procedure below. Establishing a stable zero is critical to the proper operation of the monitor. A complete calibration will include zeroing and spanning the sensor. It is generally unnecessary to set the zero at every calibration; however, it should be done during the initial installation.

### 7.11 Ozone Zero Cal

Ozone sensors have extremely low offset currents at zero. For this reason, it is normally sufficient to simply leave the zero at the factory default of 0.0 nA. As an alternative, an electronic zero can be set by disconnecting the sensor from the cable and performing steps 1-5 below.

The steps below assume that the sensor has been prepared in accordance with section 5.1, Sensor Assembly, earlier in this manual. Note that the 8 hour waiting time in step 2 below is not required if the monitor has been running for 24 hours prior to zeroing. If the unit has been running with the sensor connected, the sensor will normally return to a stable zero within 15 minutes.

1. Connect the sensor to the electronics by plugging the cable plug into the receptacle on the top of the sensor.
2. Place about an inch of water in a small beaker or other convenient container and immerse the tip of the sensor. The water used need not be distilled, but it must not contain dissolved ozone. For submersible sensors, submerge the entire sensor in a bucket of non-ozonated water. Allow the sensor to sit undisturbed for at least 8 hours.
3. Scroll to the CAL menu section using the MENU key and press ENTER or the UP arrow key. **Cal Ozone** will then be displayed.
4. Press the ENTER key. The screen will display a flashing **1-Ref** for span calibration or a **2-Zer** for zero calibration. Using the UP arrow key, set for a **2-Zer** zero calibration and press ENTER.

The system now begins acquiring data for the sensor zero calibration value. As data is gathered, the units for sensor current in nanoamps (nA) and temperature may flash. Flashing units indicate that this parameter is unstable. The calibration data point acquisition will stop only when the data remains stable for a pre-determined amount of time. This can be overridden by pressing ENTER. If the data remains unstable for 10 minutes, the calibration will fail and the message **Cal Unstable** will be displayed.

5. If accepted, the screen will display the message **PASS** with the new sensor zero reading (offset), then it will return to the main measurement display. If the calibration fails, a message indicating the cause of the failure will be displayed and the FAIL icon will be turned on. The range of acceptable value for sensor offset is -25nA to +25 nA. Should a FAIL occur, carefully inspect the sensor for a tear in the membrane. It will probably be necessary to rebuild the sensor as described in section 5.1, Ozone Sensor Assembly. Should the offset value remain high and result in calibration failures, review the Service section of this manual, and then contact the service dept. at ATI for further assistance.

The sensor zero offset value in nA from the last zero calibration is displayed on the lower line of the Default Menus for information purposes.

## 7.12 Ozone Span Cal

Span calibration of the system must be done against a laboratory measurement on the same sample that the sensor is measuring. A sample should be collected from the inlet line feeding the flow cell and quickly analyzed for ozone. When calibrating, it is best to have a reasonably high concentration of ozone in the system. The higher the value, the smaller will be the calibration errors caused by errors in the laboratory analytical procedure. It is generally preferable to calibrate at values above 0.5 PPM to reduce calibration errors. If possible, the indigo colorimetric procedure for ozone should be used as the reference method. The ozone monitor should be calibrated while operating on an ozonated sample stream in the flow cell assembly.

Start flow cell and calibrate system as follows:

1. Place the previously zeroed sensor into the sensor chamber of the flow cell assembly. The sensor is inserted into the side of the flow cell and is sealed in place with a double o-ring. The o-rings are lubricated at the factory to allow the sensor to slide smoothly into place. If insertion becomes difficult, use a small amount of silicon grease to lubricate the o-rings. If the low-volume flow cell is used, screw the sensor into the flow cell until the membrane cap bottoms out on the acrylic flow cell. Do not over-tighten
2. Turn on the inlet water flow to the flow cell and adjust the inlet flow rate so that water is overflowing from the inlet chamber. The best performance will be obtained when some water is always overflowing. This maintains constant flow and pressure on the sensor at all times.
3. Allow the system to operate undisturbed for 30-60 minutes. Assuming the water contains ozone, the display will be reading positive sensor current values. If the system is stable, the value on the display will increase to some PPM value and remain at that level. At that point, calibration can continue.
4. If the sensor is on-line, the user may want to set the output HOLD feature prior to calibration to lock out any output fluctuations.
5. Scroll to the CAL menu section using the MENU key and press ENTER or the UP arrow key. **Cal Ozone** will then be displayed.
6. Press the ENTER key. The screen will display a flashing **1-Ref** for span calibration or a **2-Zer** for zero calibration. Using the UP arrow key, set for a **1-Ref** span calibration and press ENTER.
7. The system now begins acquiring data for the calibration value. As data is gathered, the units for ppm and temperature may flash. Flashing units indicate that this parameter is unstable. The calibration data point acquisition will stop only when the data remains stable for a pre-determined amount of time. This can be overridden by pressing ENTER. If the data remains unstable for 10 minutes, the calibration will fail and the message **Cal Unstable** will be displayed.
8. The screen will display the last measured ppm value and a message will be displayed prompting the user for the lab value. The user must then modify the screen value with the arrow keys and press ENTER. The system then performs the proper checks.

9. If accepted, the screen will display the message **PASS** with the new sensor slope reading, then it will return to the main measurement display. If the calibration fails, a message indicating the cause of the failure will be displayed and the FAIL icon will be turned on. The range of acceptable values for sensor slope is 20% to 500%. It may be necessary to rebuild the sensor as described in section 5.1, Ozone Sensor Assembly. Should the slope value remain out of range and result in calibration failures, review the Service Section of this manual, then contact the service dept. at ATI for further assistance.

The sensor offset value in % from the last span calibration is displayed on the lower line of the Default Menus for information purposes.

## 7.2 Temperature Calibration

The temperature calibration sequence is essentially a 1-point offset calibration that allows adjustments of approximately  $\pm 5$  °C.

The sensor temperature may be calibrated on line, or the sensor can be removed from the process and placed into a known solution temperature reference. In any case, it is critical that the sensor be allowed to reach temperature equilibrium with the solution in order to provide the highest accuracy. When moving the sensor between widely different temperature conditions, it may be necessary to allow the sensor to stabilize as much as one hour before the calibration sequence is initiated. If the sensor is on-line, the user may want to set the output HOLD feature prior to calibration to lock out any output fluctuations.

1. Scroll to the CAL menu section using the MENU key and press ENTER or the UP arrow key.
2. Press the UP arrow key until **Cal Temp** is displayed.
3. Press the ENTER key. The message **Place sensor in solution then press ENTER** will be displayed. Move the sensor into the calibration reference (if it hasn't been moved already) and wait for temperature equilibrium to be achieved. Press ENTER to begin the calibration sequence.
4. The calibration data gathering process will begin. The message **Wait** will flash as data is accumulated and analyzed. The °C or °F symbol may flash periodically if the reading is too unstable.

5. The message **Adjust value - press ENTER** will be displayed, and the right-most digit will begin to flash, indicating that the value can be modified. Using the UP and LEFT arrow keys, modify the value to the known ref solution temperature. Adjustments up to  $\pm 5$  °C from the factory calibrated temperature are allowed. Press ENTER.

Once completed, the display will indicate **PASS** or **FAIL**. If the unit fails, the temperature adjustment may be out of range, the sensor may not have achieved complete temperature equilibrium, or there may be a problem with the temperature element. In the event of calibration failure, it is recommended to attempt the calibration again immediately.

### 7.3 pH Calibration

The pH calibration menus will not be seen unless the optional pH sensor input is turned ON and a special pH sensor is connected to the input of the instrument. See section 6.24 – pH Input for more details.

The pH calibration functions appear in the CAL menu listing when the optional pH input is enabled in the CONFIG menu. When enabled, the pH input signal is used to compensate the ozone signal. Calibration of pH is performed in one of two methods; one-point or two-point. For new sensors or for calibration in two different pH buffers with the sensor removed from the process, choose a two-point calibration. For on-line calibrations with the sensor still mounted in the process, choose a one-point calibration. For two-point calibrations, it is highly recommended to use fresh pH buffers of 7 pH and 9.18 pH.

#### 7.31 Two-Point pH Cal

1. Thoroughly clean the pH sensor and place it into the first pH calibration buffer, stirring it several times before letting it rest in the beaker. Allow sensor to sit in solution long enough to achieve temperature equilibrium with the pH buffer (maybe 5 minutes.) It is important that both pH buffers be fresh and at room temperature.
2. Scroll to the CAL menu section using the MENU key and press ENTER or the UP arrow key.
3. Press the UP arrow key until **Cal pH Type** is displayed.
4. Press the ENTER key. The display will begin to flash. Using the UP arrow key, adjust the displayed number to a **2** pt calibration type. This will allow the user to offset+slope adjust the sensor input for two separate pH point. Once value has been adjusted, press the ENTER key and the message **Accepted!** will be displayed.

5. Scroll to the next menu item by pressing the UP arrow key once. The menu item **Cal pH buf1** will be displayed.
6. Press the ENTER key. The display will begin to flash. Using the UP and LEFT arrow keys, adjust the displayed number to the known value of the pH buffer. The exact temperature compensated number for pH buffers is typically written on the side of the buffers shipping container. Once value has been adjusted, press the ENTER key.
7. The message **Accepted!** will be displayed, or an error describing the cause the failure. If the cal point was accepted, rinse the sensor in distilled or de-ionized water and move it into the second pH buffer. Stir it slightly several times and let the sensor rest in the beaker.
8. Scroll to the next menu item by pressing the UP arrow key once. The menu item **Cal pH buf2** will be displayed.
9. Press the ENTER key. The display will begin to flash. Using the UP and LEFT arrow keys, adjust the displayed number to the known value of the second (higher or lower value) pH buffer. Once value has been adjusted, press the ENTER key.
10. The message **Accepted!** will be displayed, or an error describing the cause the failure. The system is now two-point calibrated for pH.

### 7.32 One-Point pH Cal

1. For this calibration method, the sensor may be removed, cleaned, and placed into a known pH buffer, or, it may be calibrated on-line against a known reference value. If the sensor is removed, thoroughly clean the pH sensor and place it into the pH calibration buffer, stirring is several times before letting it rest in the beaker. Allow sensor to sit in solution long enough to achieve temperature equilibrium with the pH buffer (maybe 5 minutes.) It is important that the pH buffer be fresh and at room temperature.
2. Scroll to the CAL menu section using the MENU key and press ENTER or the UP arrow key.
3. Press the UP arrow key until **Cal pH Type** is displayed.

Press the ENTER key. The display will begin to flash. Using the UP arrow key, adjust the displayed number to a 1 pt calibration type. This will allow the user to offset-adjust the sensor input for one pH point. Once value has been adjusted, press the ENTER key and the message **Accepted!** will be displayed.

4. Scroll to the next menu item by pressing the UP arrow key once. The menu item **Cal pH buf1** will be displayed.
5. Press the ENTER key. The display will begin to flash. Using the UP and LEFT arrow keys, adjust the displayed number to the known value of the pH buffer. If the sensor is still mounted in the process, enter the known reference value. The exact temperature compensated number for pH buffers is typically written on the side of the buffers shipping container. Once value has been adjusted, press the ENTER key.
6. The message **Accepted!** will be displayed, or an error describing the cause of the failure. The system is now two-point calibrated for pH.

## Part 8 – PID Controller Details

---

### 8.1 PID Description

PID control, like many other control schemes, are used in chemical control to improve the efficiency of chemical addition or control. By properly tuning the control loop that controls chemical addition, only the amount of chemical that is truly required is added to the system, saving money. The savings can be substantial when compared to a system which may be simply adding chemical at a constant rate to maintain some minimal addition under even the worst case conditions. The PID output controller is highly advantageous over simple control schemes that just utilize direct (proportional only) 4-20 mA output connections for control, since the PID controller can automatically adjust the “rate” of recovery based on the error between the setpoint and the measured value – which can be a substantial efficiency improvement..

The PID controller is basically designed to provide a “servo” action on the 4-20 mA output to control a process. If the user requires that a measured process stay as close as possible to a specific setpoint value, the controller output will change from 0% to 100% in an effort to keep the process at the setpoint. To affect this control, the controller must be used with properly selected control elements (valves, proper chemicals, etc.) that enable the controller to add or subtract chemical rapidly enough. This is not only specific to pumps and valves, but also to line sizes, delays in the system, etc.

This section is included to give a brief description of tuning details for the PID controller, and is not intended to be an exhaustive analysis of the complexities of PID loop tuning. Numerous sources are available for specialized methods of tuning that are appropriate for a specific application.

### 8.2 PID Algorithm

As most users of PID controllers realize, the terminology for the actual algorithm terms and even the algorithms themselves can vary between different manufacturers. This is important to recognize as early as possible, since just plugging in similar values from one controller into another can result in dramatically different results. There are various basic forms of PID algorithms that are commonly seen, and the implementation here is the most common version; The ISA algorithm (commonly referred to as the “ideal” algorithm.)

$$\text{output} = P \left[ e(t) + \frac{1}{I} \int e(t) dt + D \frac{de(t)}{dt} \right]$$

Where:

output =	controller output
P =	proportional gain
I =	integral gain
D =	derivative gain
t =	time
e(t) =	controller error (e=measured variable – setpoint)

### **Figure 8-1 Q45H ISA (Ideal) PID Equation**

The most notable feature of the algorithm is the fact the proportional gain term affects all components directly (unlike some other algorithms - like the “series” form.) If a pre-existing controller utilizes the same form of the algorithm shown above, it is likely similar settings can for made if the units on the settings are exactly the same. Be careful of this, as many times the units are the reciprocals of each other (i.e. reps-per-min, sec-per-rep.)

PID stands for “proportional, integral, derivative.” These terms describe the three elements of the complete controller action, and each contributes a specific reaction in the control process. The PID controller is designed to be primarily used in a “closed-loop” control scheme, where the output of the controller directly affects the input through some control device, such as a pump, valve, etc.

Although the three components of the PID are described in the setting area (section 6.25), here are more general descriptions of what each of the PID elements contribute to the overall action of the controller.

- P Proportional gain. With no “I” or “D” contribution, the controller output is simply a factor of the proportional gain multiplied by the input error (difference between the measured input and the controller setpoint.) Because a typical chemical control loop cannot react instantaneously to a correction signal, proportional gain is typically not efficient by itself – it must be combined with some integral action to be useful. Set the P term to a number between 2-4 to start. Higher numbers will cause the controller action to be quicker.
  
- I Integral gain. Integral gain is what allows the controller to eventually drive the input error to zero – providing accuracy to the control loop. It must be used to affect the accuracy in the servo action of the controller. Like proportional gain, increasing integral gain results in the control action happening quicker. Set the I term to a number between 3-5 to start (1-2 more than P). Like proportional gain, increasing the integral term will cause the controller action to be quicker.

- D Derivative gain. The addition of derivative control can be problematic in many applications, because it greatly contributes to oscillatory behavior. In inherently slow chemical control processes, differential control is generally added in very small amounts to suppress erratic actions in the process that are non-continuous, such as pumps and valves clicking on and off. However, as a starting point for chemical process control, its best to leave the “D” term set to 0.

Based on these descriptions, the focus on tuning for chemical applications really only involves adjustment of “P” and “I” in most cases. However, increasing both increases the response of the controller. The difference is in the time of recovery. Although combinations of high “P’s” and low “I” will appear to operate the same as combinations of low “P’s” and high “I’s”, there will be a difference in rate of recovery and stability. Because of the way the algorithm is structured, large “P’s” can have a larger impact to instability, because the proportional gain term impacts all the other terms directly. Therefore, keep proportional gain lower to start and increase integral gain to achieve the effect required.

Many of the classical tuning techniques have the user start with all values at 0, and then increase the P term until oscillations occur. The P value is then reduced to  $\frac{1}{2}$  of the oscillatory value, and the I term is increased to give the desired response. This can be done with the Q45H controller, with the exception that the I term should start no lower than 1.0.

If it appears that even large amounts of integral gain (>20) don’t appreciably increase the desired response, drop I back to about 1.0, and increase P by 1.00, and start increasing I again. In most chemical control schemes, I will be approximately 3 times the value of P.

### 8.3 Classical PID Tuning

Unlike many high speed position applications where PID loops are commonly used, the chemical feed application employed by this instrument does not require intense mathematical exercise to determine tuning parameters for the PID. In fact, the risk of instability is far greater with overly tuned PID control schemes. In addition, many of the classical mathematical exercises can be damaging or wasteful in the use of chemicals when the process is bumped with large amounts of input error to seek a response curve. Because of this, the general adjustment guidelines described in section 8.2 are sufficient for almost all application tuning for this instrument. Beyond this, many sources are available for classical tuning methods.

## 8.4 Common PID Pitfalls

The most common problem occurring in PID control applications involves the false belief that proper settings on only the PID controller can balance any process to an efficient level.

Close-loop control can only be effective if all elements in the loop are properly selected for the application, and the process behavior is properly understood. Luckily, the nature of simple chemical control processes are generally slow in nature. Therefore, even a de-tuned controller (one that responds somewhat slow) can still provide substantial improvements to setpoint control. In fact, damaging oscillatory behavior is far more likely in tightly tuned controllers where the user attempted to increase response too much.

When deciding on a PID control scheme, it is important to initially review all elements of the process. Sticking valves, undersized pumps, or delays in reaction times associated with chemical addition can have a dramatic effect on the stability of the control loop. When controlling a chemical mix or reaction, the sensor should be placed in a location that ensures proper mixing or reaction time has occurred.

The easiest processes to control with closed-loop schemes are generally linear, and symmetrical, in nature. For example, controlling level in tank where the opening of valve for a fixed period of time corresponds linearly to the amount that flows into a tank. Chemical control processes can be more problematic when the nature of the setpoint value is non-linear relative to the input of chemical added. For example, pH control of a process may appear linear only in a certain range of operation, and become highly exponential at the extreme ranges of the measuring scale. In addition, if a chemical process is not symmetrical, that means it responds differentially to the addition and subtraction of chemical. It is important in these applications to study steady-state impact as well as step-change impact to process changes. In other words, once the process has apparently been tuned under normal operating conditions, the user should attempt to force a dramatic change to the input to study how the output reacts. If this is difficult to do with the actual process input (the recommended method), the user can place the control in manual at an extreme control point such as 5% or 95%, and release it in manual. The recovery should not be overly oscillatory. If so, the loop needs to be de-tuned to deal with that condition (reduce P and/or I.)

## Part 9 – System Maintenance

---

### 9.1 General

The Q45H/64 Dissolved Ozone System will generally provide unattended operation over long periods of time. With proper care, the system should continue to provide measurements indefinitely. For reliable operation, maintenance on the system must be done on a regular schedule. Keep in mind that preventive maintenance on a regular schedule is much less troublesome than emergency maintenance that always seems to come at the wrong time.

### 9.2 Analyzer Maintenance

No unusual maintenance of the analyzer is required if installed according to the guidelines of this operating manual. If the enclosure door is frequently opened and closed, it would be wise to periodically inspect the enclosure sealing gasket for breaks or tears.

### 9.3 Ozone Sensor Maintenance

Sensor maintenance is required for accurate measurements. The primary requirement is simply to keep the sensor membrane clean. The membrane is a micro-porous polymer that is resistant to anything that will be encountered in water streams. However, deposits can form on the surface or in the pores of the membrane, and these deposits will reduce the sensitivity. Certain constituents in water, mainly iron and manganese will form precipitates. These precipitates can sometimes form a coating on the membrane.

Because membranes are micro-porous, they can be relatively difficult to clean effectively. Immersing the tip of the sensor in 1N nitric acid solution will sometimes remove deposits that cause low sensitivity, but this is not always the case. The recommended practice is to simply replace the membrane when it becomes fouled. To change a membrane, follow the Sensor Assembly procedure (Section 5.1). Do not reuse the electrolyte from the sensor when changing a membrane. Always refill with fresh electrolyte. The electrolyte is stable and does not have a limited shelf life.

Refer again to the explanation of the sensor slope number after an accepted span calibration on the lower MEASURE screen. In normal operation, the slope of the sensor output will decrease over time as the membrane becomes fouled. This reduction indicates that the sensor is losing sensitivity to ozone. It is good practice to replace the membrane if the slope number falls to 30-40%. The value will not go below 20%.

Even if no buildup is apparent on the membrane, it should be changed on a regular schedule. The recommended membrane change interval is every 3 months. For high purity water applications, this can probably be extended if desired, but a more frequent changing interval is a small price to pay for avoiding membrane failure at the wrong time.

While the sensor is disassembled for membrane changing, examine the condition of the o-rings on both ends of the electrolyte chamber. If the o-rings show any signs of damage, replace them with new ones from the spare parts kit. It is good practice to change these o-rings once a year, regardless of their condition.

### 9.31 Sensor Acid Cleaning

Over an extended operating period, ozone sensors can slowly accumulate deposits on the surface of the platinum electrode. Typically, this type of buildup occurs over years of operation, but can sometimes occur more quickly in high levels of manganese, iron, or other metals are dissolved in the water. The platinum electrode can be “acid cleaned” using nitric acid solutions.

## WARNING

**THIS ACID CLEANING PROCEDURE INVOLVES THE USE OF HIGHLY CORROSIVE ACID SOLUTIONS. IT SHOULD ONLY BE COMPLETED BY TRAINED PERSONNEL USING PROTECTIVE EYEWEAR AND GLOVES. IF THERE IS ANY DOUBT ABOUT YOUR ABILITY TO SAFELY ACCOMPLISH THIS PROCEDURE, RETURN THE SENSOR TO ATI FOR FACTORY CLEANING!**

To acid clean the electrode assembly, remove the electrolyte chamber from the sensor so that the so that both electrodes are exposed. Then follow the procedure below.

1. Place a small amount of 50% nitric acid solution in a beaker. Put in just enough so that the platinum tip of the sensor can be submerged without any contact with the silver coil.
2. Allow the sensor to soak in this acid solution for 2 minutes. Remove the sensor body and rinse the platinum tip thoroughly with distilled water. Discard the nitric acid safely and according to all environmental regulations.

3. Fill the beaker with distilled water to the level sufficient to submerge both the tip and the silver coil. Do not allow the connector at the back of the sensor to be submerged. Allow the electrodes to soak in distilled water for 30 minutes.
4. Put a new membrane and fresh electrolyte in the electrolyte chamber and reassemble the sensor. Connect to the ozone monitor electronics and allow the sensor to stabilize for at least 24 hours. The sensor can be placed in the flow cell with ozonated water running through it during stabilization. However, the readings will not be useful for 24 hours.

#### 9.4 Flow Cell Maintenance

The maintenance on the flow cell is simple cleaning. The flow cell is clear to make examination of the condition of the sensor easier without interfering with operations. The flow cell may be cleaned by wiping or by washing with detergents or dilute acids. Do not try to clean with solvents as the acrylic may craze or crack.

Change the o-ring in the flow cell yearly or if any damage is observed. If insertion of the sensor into the flow cell becomes difficult, use silicon grease to lubricate the o-rings that hold the sensor in place. Use only enough grease to provide surface lubrication. Excess grease could foul the sensor membrane.

## Part 10 – Troubleshooting

---

### 10.1 General

The information included in this section is intended to be used in an attempt to quickly resolve an operational problem with the system. During any troubleshooting process, it will save the most time if the operator can first determine if the problem is related to the analyzer, sensor, or some external source. Therefore, this section is organized from the approach of excluding any likely external sources, isolating the analyzer, and finally isolating the sensor. If these procedures still do not resolve the operational problems, any results the operator may have noted here will be very helpful when discussing the problem with the factory technical support group.

### 10.2 External Sources of Problems

To begin this process, review the connections of the system to all external connections.

1. Verify the analyzer is earth grounded. For all configurations of the analyzer, an earth ground connection **MUST** be present for the shielding systems in the electronics to be active. Grounded conduit provides no earth connection to the plastic enclosure, so an earth ground wiring connection must be made at the power input terminal strip. Verify metal shield is present over incoming power connections. This shield is for safety purposes, but also blocks electrical spikes from relay and power wiring.
2. Verify the proper power input is present (115/230/16-35VDC).
3. Verify the loads on any 4-20 mA outputs do not exceed the limits in the Instrument Specifications. During troubleshooting, it is many times helpful to disconnect all these outputs and place wire-shorts across the terminals in the instrument to isolate the system and evaluate any problems which may be coming down the analog output connections.
4. Do not run sensor cables or analog output wiring in the same conduits as power wiring. If low voltage signal cables must come near power wiring, cross them at 90° to minimize coupling.
5. If rigid conduit has been run directly to the Q45 enclosure, check for signs that moisture has followed conduit into the enclosure.

6. Check for ground loops. Although the membrane sensor is electrically isolated from the process water, high frequency sources of electrical noise may still cause erratic behavior in extreme conditions. If readings are very erratic after wiring has been checked, check for a possible AC ground loop by temporarily disconnecting feed and drain lines from the flow cell while there is still water on the inside. The reading should be initially stable and then fall very slowly in a smooth fashion as ozone is depleted in the static sample.
7. On relay based systems, check the load that is connected to the relay contacts. Verify the load is within the contact rating of the relays. Relay contacts which have been used for higher power AC current loads may become unsuitable for very low signal DC loads later on because a small amount of pitting can form on the contacts. If the load is highly inductive (solenoids, motor starters, large aux relays), note that the contact rating will be de-rated to a lower level. Also, due to the large amount of energy present in circuits driving these types of loads when they are switched on and off, the relay wiring placement can result in electrical interference for other devices. This can be quickly resolved by moving wiring, or by adding very inexpensive snubbers (such as Quencharcs) to the load.
8. Carefully examine any junction box connections for loose wiring or bad wire stripping. If possible, connect the sensor directly to the analyzer for testing.
9. Check sensor membrane for fouling. Look closely for signs of grease or oil which may be present. Replace membrane and electrolyte, allow to stabilize, and re-check. The procedure in Ozone Sensor Assembly, (Section 5.1), must be followed when replacing the membrane.

### 10.3 Analyzer Tests

1. Disconnect power and completely disconnect all output wiring coming from the analyzer. Remove sensor wiring, relay wiring, and analog output wiring. Re-apply power to the analyzer.
2. Using the Simulate feature, check operation of analog outputs and relays with a DMM.
3. Check cell drive circuit. With a digital voltmeter (DVM), measure the voltage between terminals 17 and 18 on the back of the monitor to verify that the millivolt value is actually -400 mV.
4. Check TC drive circuit. Place a wire-short between the GREEN and RED terminals. With a digital voltmeter (DVM), measure the voltage between the BLACK and GREEN terminals on the back of the monitor to verify that the TC

drive circuit is producing about 4.8-5.1 VDC open circuit. Remove DVM completely and connect a 100 Ohm resistor from the BLACK to GREEN terminals. The temperature reading should display approximately 0°C and the ozone reading should display approximately 0 ppm.

### 10.4 Display Messages

The Q45 Series instruments provide a number of diagnostic messages which indicate problems during normal operation and calibration. These messages appear as prompts on the secondary line of the display or as items on the Fault List.

MESSAGE	DESCRIPTION	POSSIBLE CORRECTION
<b>Max is 200</b>	Entry failed, maximum user value allowed is 200.	Reduce value to $\leq 200$
<b>Min is 200</b>	Entry failed, minimum value allowed is 200.	Increase value to $\geq 200$
<b>Cal Unstable</b>	Calibration problem, data too unstable to calibrate. Icons will not stop flashing if data is too unstable. User can bypass by pressing ENTER.	Clean sensor, get fresh cal solutions, allow temperature and conductivity readings to fully stabilize, do not handle sensor or cable during calibration.
<b>Out of Range</b>	Input value is outside selected range of the specific list item being configured.	Check manual for limits of the function to be configured.
<b>Locked!</b>	Transmitter security setting is locked.	Enter security code to allow modifications to settings.
<b>Unlocked!</b>	Transmitter security has just been unlocked.	Displayed just after security code has been entered.
<b>Offset High</b>	The sensor zero offset point is out of the acceptable range of -20 to +20 nA.	Check wiring connections to sensor. Allow sensor to operate powered a minimum of 12 hours prior to first zero cal.
<b>Sensor High</b>	The raw signal from the sensor is too high and out of instrument range.	Check wiring connections to sensor.
<b>Sensor Low</b>	The raw signal from the sensor is too low.	Check wiring connections to sensor.
<b>Ozone High</b>	The ozone reading is greater than the maximum of the User-selected range.	The ozone reading is over operating limits. Set measuring range to the next highest level.
<b>Temp High</b>	The temperature reading is $> 55^{\circ}\text{C}$ .	The temperature reading is over operating limits. Check wiring and expected temp level. Perform RTD test as described in sensor manual. Recalibrate sensor temperature element if necessary.
<b>Temp Low</b>	The temperature reading is $< -10^{\circ}\text{C}$	Same as "Temp High" above.
<b>TC Error</b>	TC may be open or shorted.	Check sensor wiring and perform RTD test as described in sensor manual. Check j-box connections.

**Figure 10-1 Q45H Display Messages**

MESSAGE	DESCRIPTION	POSSIBLE CORRECTION
<b>Ozone Cal Fail</b>	Failure of ozone calibration. FAIL icon will not extinguish until successful calibration has been performed, or 30 minutes passes with no keys being pressed.	Clean sensor redo zero and span calibration. If still failure, sensor slope may be less than 25% or greater than 250%. Perform sensor tests as described in section 10.5. Replace sensor if still failure.
<b>TC Cal Fail</b>	Failure of temperature calibration. FAIL icon will not extinguish until successful calibration has been performed, or 30 minutes passes with no keys being pressed.	Clean sensor, check cal solution temperature and repeat sensor temp calibration. TC calibration function only allows adjustments of +/- 6 °C. If still failure, perform sensor tests as described in section 10.5. Replace sensor if still failure. .
<b>EPRom Fail</b>	Internal nonvolatile memory failure	System failure, consult factory.
<b>Chcksum Fail</b>	Internal software storage error.	System failure, consult factory.
<b>Display Fail</b>	Internal display driver fail.	System failure, consult factory.
<b>Range Cal Fail</b>	Failure of factory temperature calibration.	Consult factory.

**Figure 10-1 Q45H Display Messages (continued)**

## 10.5 Sensor Tests

1. Check the membrane condition. A membrane that is not stretched smoothly across the tip of the sensor will cause unstable measurements. If necessary, change membrane and electrolyte.
2. Residual ozone sensors can be tested with a digital voltmeter (DVM) to determine if a major sensor problem exists. Follow the steps below to verify sensor integrity:
  - A. Disconnect the five sensor wires from the back of the ozone monitor. Those wires are color coded white, brown, red, black, and green. Note that the brown wire may be replaced with an orange wire in some cables.
  - B. Remove the electrolyte chamber from the sensor and dry the electrodes with a paper towel.
  - C. Connect a DVM between the white and brown (or orange) wires. Reading resistance, you should find an open circuit value of infinite resistance. There must be no measurable resistance at all between these wires. Any resistance at all indicates either water in the cable connector or the breakdown in an electrode seal.
  - D. Connect a DVM between the red and white wires. The red wire is part of the RTD circuit and the white wire is part of the measuring cell. There should be no connection. Reading resistance, you should find an open circuit value of infinite resistance. Any resistance at all indicates either water in the cable connector or the breakdown in an electrode seal.
  - E. Connect the DVM between the red and black wires. These are the RTD leads, and you should find a resistance value that depends on the temperature. The table below lists the resistance values for various temperatures. Reading resistance between the red and green wires should give exactly the same values as between red and black.

Temperature °C	Resistance Ω
0	100.0
5	101.9
10	103.9
15	105.8
20	107.8
25	109.7
30	111.7
35	113.6
40	115.5
45	117.5
50	119.4

**Figure 10-2 Pt100 RTD Table**

If you suspect that water has gotten into a cable connection on a flow type sensor or into the plug connection of a submersible sensor, disconnect the cable and allow the parts of the sensor to sit in a warm place for 24 hours. If water in the connector is the problem, it should dry out sufficiently to allow normal sensor operation. However, steps 4 and 5 above will have to be repeated after drying to see if the problem is gone.

3. Acid clean the sensor electrodes in accordance with the procedure on the previous page.

# Spare Parts

---

<u>Part No.</u>	<u>Description</u>
07-0026	2-Wire monitor electronics assembly
07-0027	AC Powered monitor electronics assembly (specify 115 or 230 VAC)
01-0242	Power supply circuit board assembly (specify 115 or 230 VAC)
00-0042	Ozone sensor, flow type
02-0018	Sensing element body, (for #00-0042)
00-0065	Ozone sensor, submersion type with 25' cable
02-0020	Submersion sensing module, (for #00-0065)
02-0019	Submersion element body, (for #02-0020)
02-0031	Submersion holder, 25' cable (for #00-0065)
03-0029	Sensor interconnect cable with connector, 25 ft.
03-0315	Vented electrolyte chamber assembly
05-0023	Combined Chlorine Membranes backed – pkg 10 (03-0315)
45-0007	Electrolyte chamber
48-0001	Membrane holder, type 316 stainless steel
45-0010	Membrane holder, <i>noryl</i>
05-0002*	Membranes, pkg. of 10
05-0004*	Spare Parts Kit, screw & o-ring
09-0008*	Dissolved ozone electrolyte, 4 oz (120 cc)
07-0096	Q22P pH Sensor with connector (not waterproof)
09-0052	Reference Solution for pH sensor (07-0096)
05-0066	Salt bridge for pH sensor (07-0096)
63-0101	25' Combination pH Sensor (w/Solution Ground)
00-0043	Constant-Head Flowcell assembly with mounting plate
42-0014	Flowcell o-ring (each)
00-0625	1½" Flow tee assembly
07-0100	Junction box
31-0038	Interconnect cable for junction box to monitor wiring
23-0018	Fuse, 100mA, 250V (115VAC)
23-0019	Fuse, 50mA, 250V (230VAC)
38-0063	Terminal block plug, 2 position (outputs)
38-0064	Terminal block plug, 6 position (relays)
38-0065	Terminal block plug, 3 position (power)
31-0173	20 Pos. Ribbon cable assembly for AC units
44-0260	Pg9 cord grip (each)
44-0263	½" NPT 2-hole cord grip
44-0274	½" NPT cord grip (each)
48-0108	2-Hole cord grip adapter

**Note:** Instrument is supplied with sufficient spare parts for 6-12 months of operation. For 2 year spare parts inventory, 3 each of the items marked with an asterisk are required.

**Lock/Unlock Code: 1456**