

25-SCFH Oxygen Concentrator

PSA Oxygen Concentrator

OG-25 Oxygen concentrator offers a reliable low cost method of providing oxygen feed gas for all your ozone generation needs. Using an oxygen concentrator eliminates the need for bottled oxygen and is much more cost effective and convenient.



Features

- 25 SCFH Oxygen at 95 %
- Dependable Operation
- Durable Construction
- Low Operating Cost
- Automatic unattended operation
- Easy to install and maintain

Product ID: **OG-25**
 Lead Time: **1 week**
 Price: **\$3,995.00**

Specifications

Flowrate	25 SCFH
Purity	Up to 95%
Pressure	45-60 PSI
Dewpoint	-100-deg F
[b]Feedgas Requirements [/ b]	
Air Flow	6.5 CFM
Pressure	90 PSI
Quality	Clean dry plant air per ISO specifications 5.7.5
Temperature	Air must be cooler than 100-deg F
Ambient Temperature	40-100-deg F
Storage tank	Oxygen Storage tank is necessary and available from Ozone Solutions
Power Requirements	120 Watts
Dimensions (W x D x H)	13-in x 16-in x 51-in
Weight	190 lbs

System Configuration

Typical System Configuration

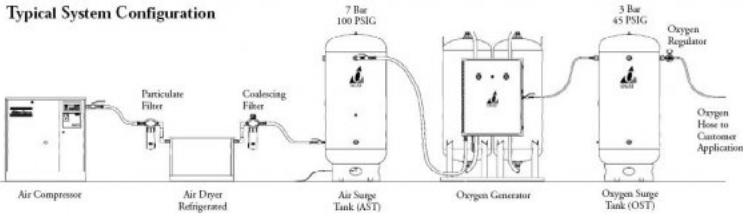

Typical system configuration shown.

Internal Diagram

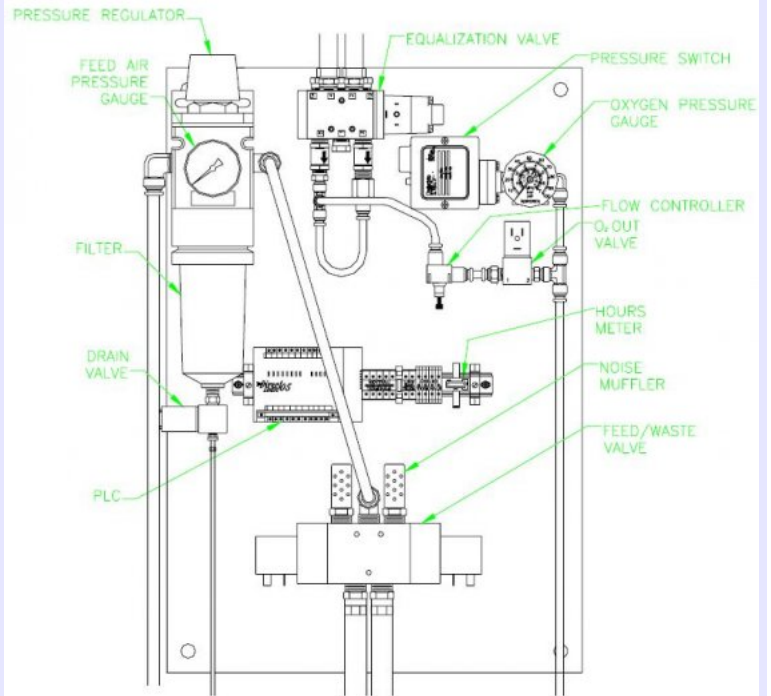
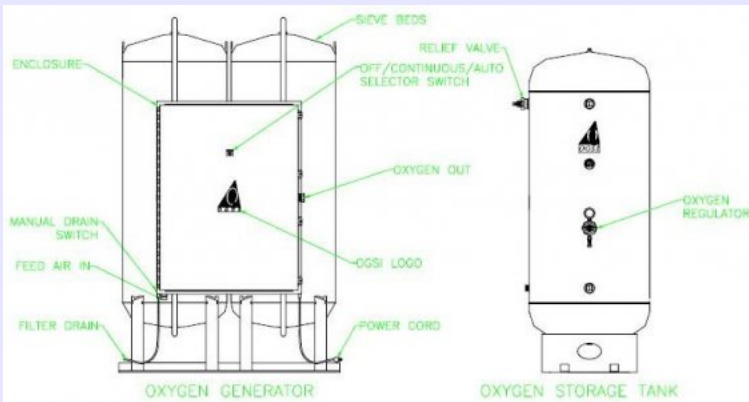

Diagram of the internal parts of the OG-25 control panel

External System Diagram



External System Diagram shows the OG-25 with the oxygen storage tank.

Process Flow Diagram

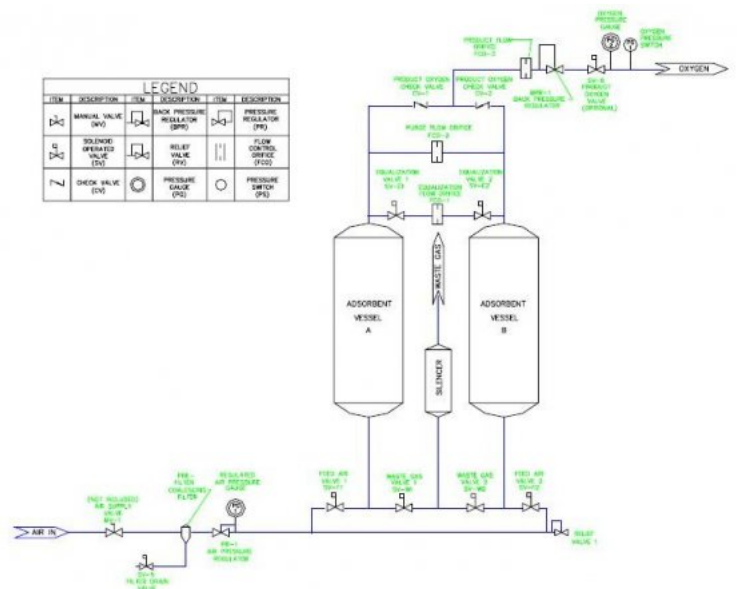

System process flow diagram